

GLL SKQUA1.5 BR

QUARTZ Sink Range Gallery Quartz Easyfit Sink 1.5 Bowl Black Right Drainer



Specification

Main Construction Material:	Composite Resin
Number of Tap Holes:	1
Product Finish:	Black
Sink Type:	1.5 Bowl
Connection Inlet:	1/2" BSP Flexible Tails
Connection Outlet:	G 1 1/2"
Product Orientation:	Right Drainer
Drainage Flow Rate (litres per minute)	37.2

Features:

- Easy installation: pre-fitted with Easyfit tap base, flexible inlet pipes and isolators
- Everything you need: strainer waste, overflow, pipework and fixings included
- Made to last: Highly durable 80% Quartz, anti-bacterial composite material
- Includes cutting-hole template
- 25 year guarantee (Easyfit base 10 years*)

Product Certifications:



For more products, visit our website:
<http://www.bristan.com>



Dimensions (measurements in mm)

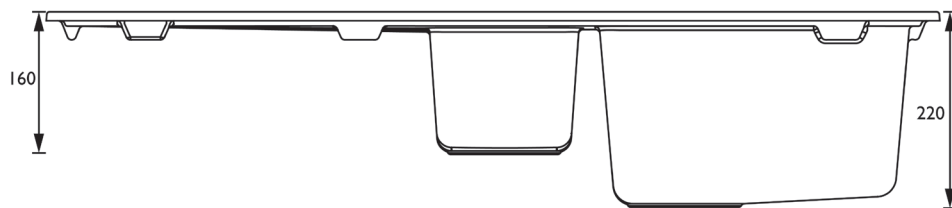
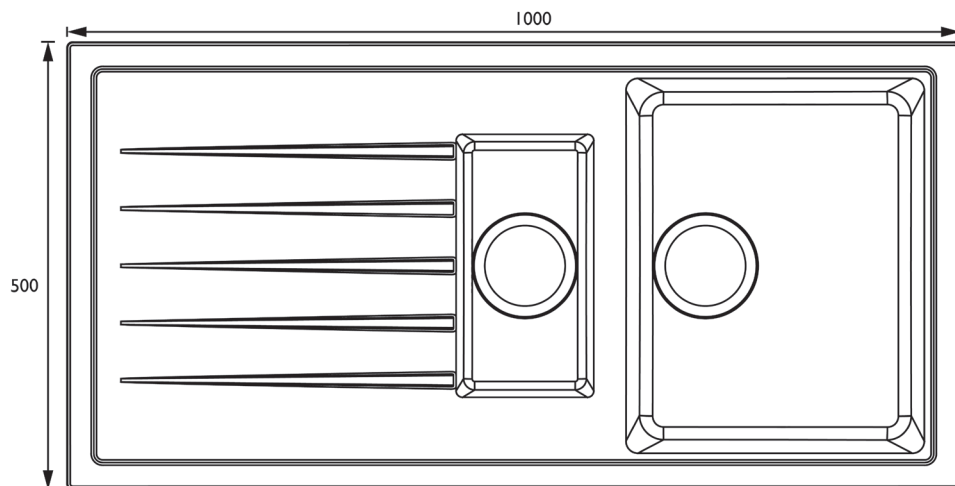

Minimum Cabinet Width: 600mm

TECHNICAL DATA SHEET



Kitchen Sinks Easyfit Base Easyfit Base* Waste kit

BRISTAN

TAPS & SHOWERS D3

Bristan, Birch Coppice Business Park, Dordon, Tamworth, B78 1SG. Web Site: www.bristan.com Telephone: 0330 026 6273. Email: enquire@bristan.com.

* - 10 year guarantee applies to products purchased on or after 01/04/2021. The information contained on this page was correct at date of issue. Fitting Dimensions are provided as a guide only. Some variation may occur due to manufacturing tolerances. Bristan pursues a policy of continuous improvement in design and performance of its products and so reserves the right to change specifications without prior notice.