

BRISTAN

Installation Instructions & User Guide

Please leave these instructions with the end user

Product Code: PS2 BF C (D2)

Specifications

Dynamic Water Pressure

Min: 0.3 bar Max: 5.0 bar

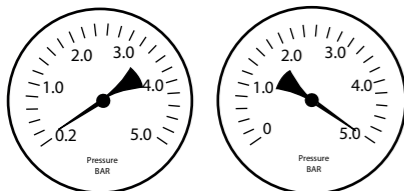

Maximum Static Pressure: 10.0 bar

Inlet Water Temperature

Cold Water Supply

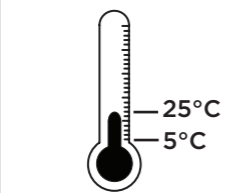

Min: 5°C Max: 25°C

Hot Water Supply

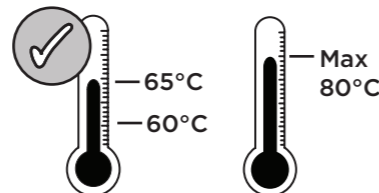

60-65°C Recommended
80°C Maximum

Inlet Dimensions

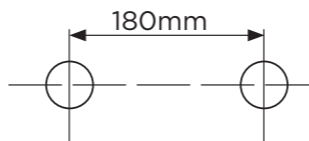

Inlet Connection



3/4" Male BSP Tap Connector

Tools You'll Need

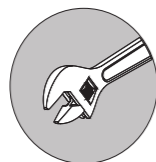

Adjustable Spanner



Pipe Cutter

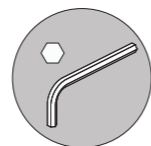

Hexagonal Keys

Prior to Installation

All products manufactured and supplied by Bristan are safe provided they are installed, used correctly and receive regular maintenance in accordance with these instructions.

This product has been tested to the Water Regulations Advisory Scheme (WRAS) and satisfies the requirements of the Water Supply (Water Fittings) Regulations 1999 and current bylaws.

For full Installation Requirements & Notes (IRN) please visit www.wras.co.uk/directory

Isolation valves must be fitted to the inlet water supplies to ensure ease of future maintenance.

Before installing these taps the water supply must be thoroughly flushed in order to remove any swarf, solder etc from the pipework.

Pack Contents

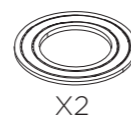
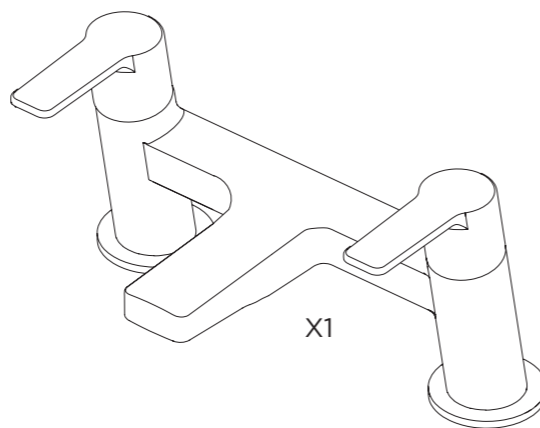

Installation

1

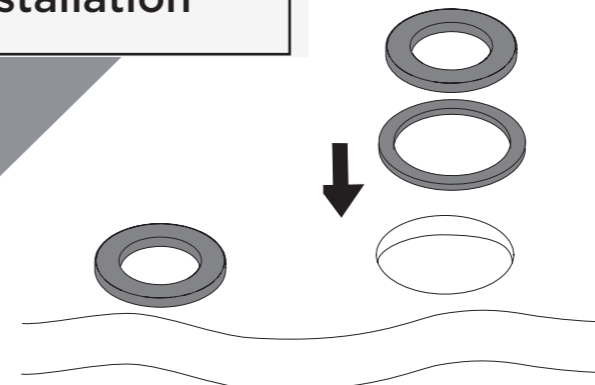

Place the plinths over the holes in the bath ensuring that the washers are fitted between the plinths and the bath.

2

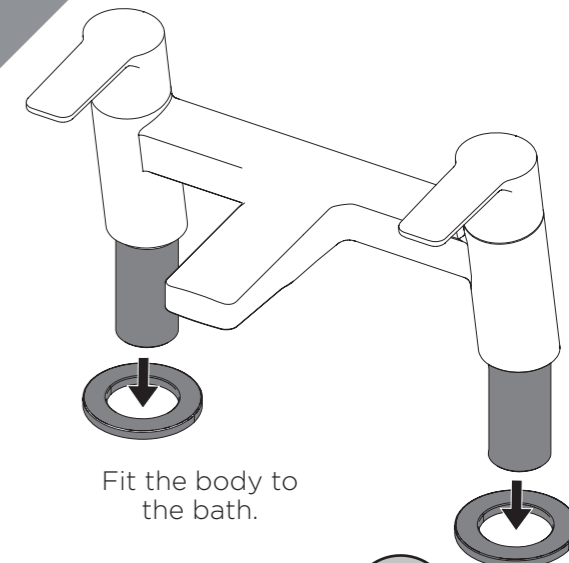

Fit the body to the bath.

3

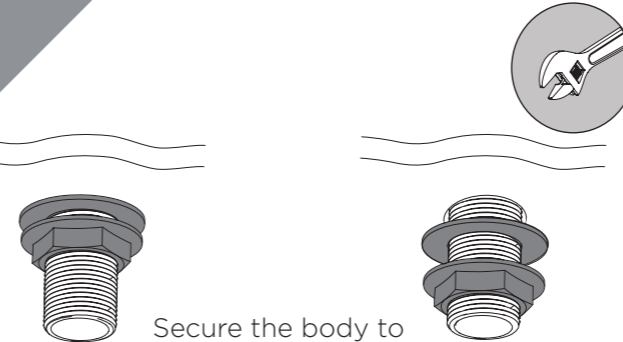

Secure the body to the bath by using the washer and metal backnut below the bath. Tighten the backnut onto the threaded tails.

4

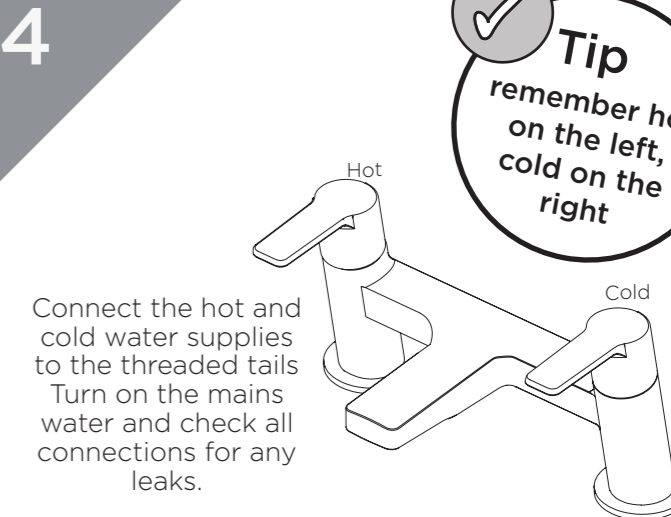

Connect the hot and cold water supplies to the threaded tails. Turn on the mains water and check all connections for any leaks.

Operation

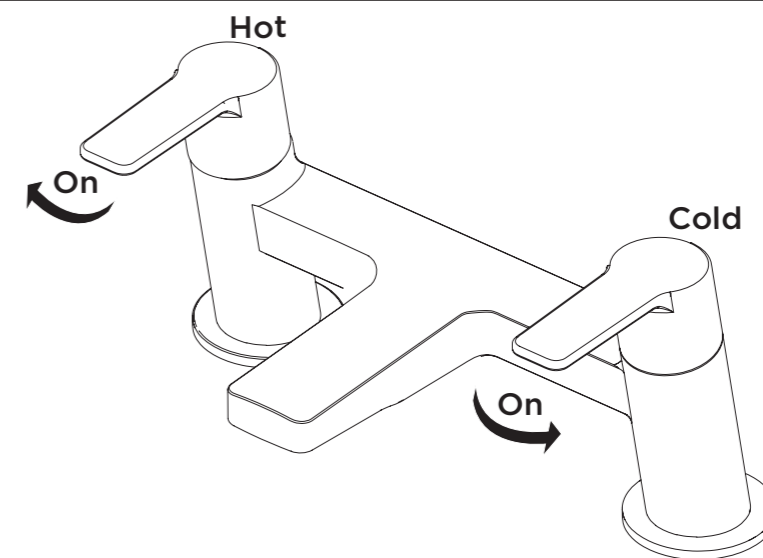

Why not visit our YouTube channel

To see our latest how-to videos, simply scan the QR code with your smart phone or tablet.



Alternatively visit www.youtube.com/bristanTV

Maintenance - Cartridge Cleaning

1

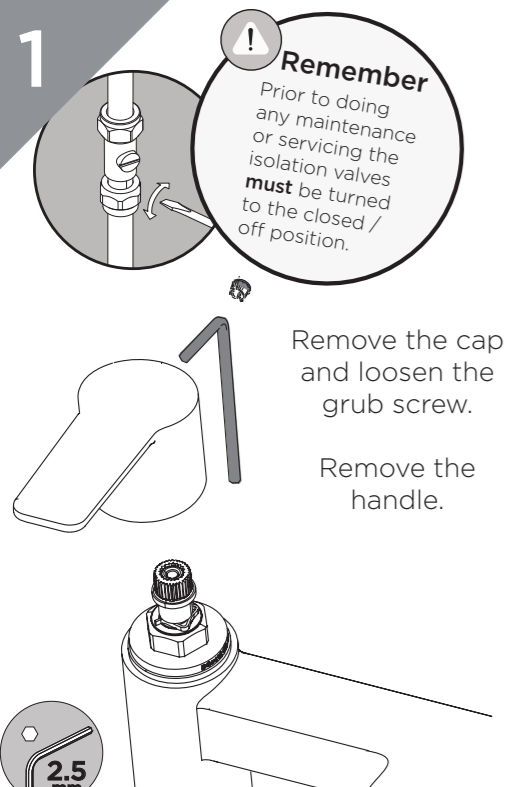

Remember
Prior to doing any maintenance or servicing the isolation valves **must** be turned to the closed / off position.

Remove the cap and loosen the grub screw.

Remove the handle.

2

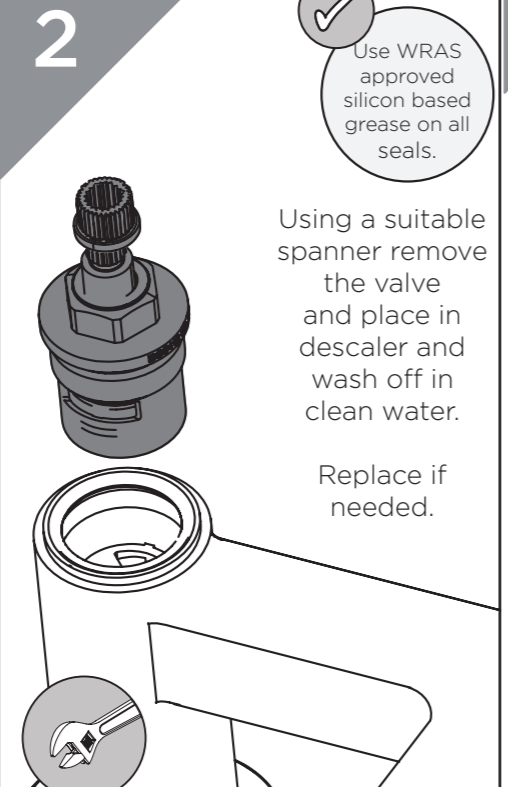

Use WRAS approved silicon based grease on all seals.

Using a suitable spanner remove the valve and place in descaler and wash off in clean water.

Replace if needed.

3

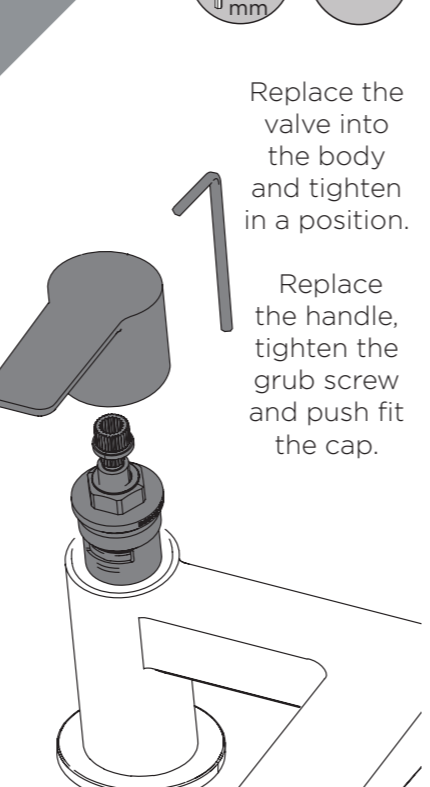

Replace the valve into the body and tighten in a position.

Replace the handle, tighten the grub screw and push fit the cap.

Maintenance - Flow Straightener

1

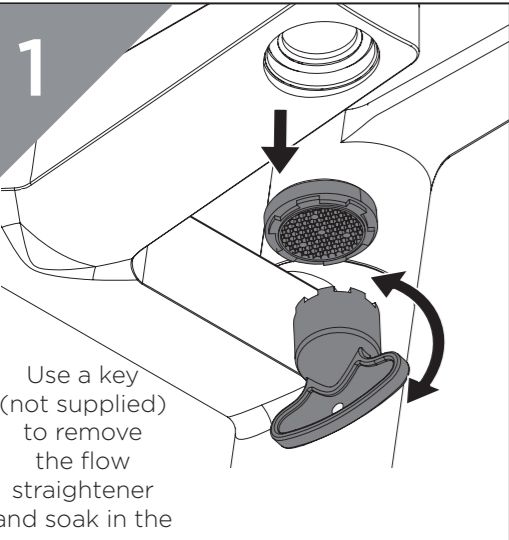

Use a key (not supplied) to remove the flow straightener and soak in the descaler.

2

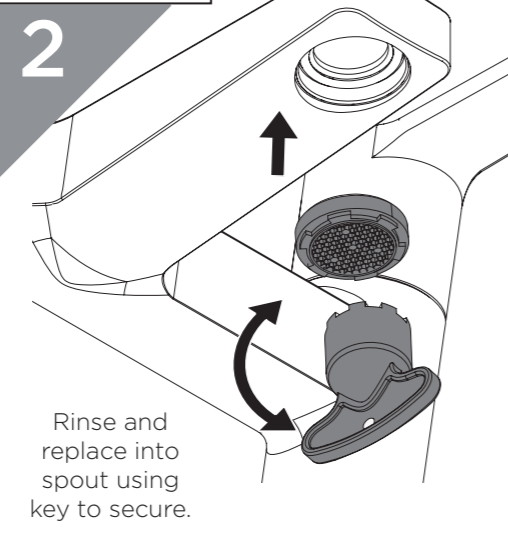

Rinse and replace into spout using key to secure.

Spares

To replace any spare parts for your bath filler why not scan the QR code and search for your product



General Cleaning

Your fitting has a high quality finish and should be treated with care to preserve the visible surfaces.

All surfaces will wear if not cleaned correctly, the only safe way to clean your mixer tap is to wipe with a soft damp cloth. Stains can be removed using washing up liquid. All bath cleaning powders and liquids will damage the surface of your fitting, even the non-scratch cleaners.

Note: Never use abrasive detergents or disinfectants or those containing alcohol, hydrochloric acid or phosphoric acid.

Troubleshooting

Symptom	Cause(s)	Remedy
No flow or low flow rate	Partially closed isolation valve.	Open isolation valve.
	Instantaneous water heater cycles on and off as flow rate or pressure is too low.	Increase water flow rate or pressure through system.
	Head of water is below the minimum distance required.	Refer to the specification for the minimum distance required
	Hot or cold water being drawn off elsewhere causing pressure changes or instantaneous boiler temperature changes.	Do not use other water outlets when using the taps.
	Airlock or partial blockage in the supply pipework.	Flush through pipework to ensure removal of debris and any airlocks.
	Water supply failure, please check below:	Investigate water supply. Check your plumbing and heating systems for any faults.
	When handle is in Hot Position	
When handle is in Mixed position	fault on either hot and/or cold water supply. Tap will not run in this position due to inability to mix water	
When handle is in Cold position	fault on the cold water supply. Hot water will still continue to run.	
Water dripping from taps	This is normal for a short time after using the taps.	This is caused by capillary action, the build up of water in the tap body.
	If water continues to drip, possibly due to the ceramic disc valves/cartridge	Refer to the section: Maintenance - Cleaning/ Replacing Cartridge
Taps do not turn on	Closed isolation valve.	Open isolation valve.
	Mains water supply turned off.	Turn on mains water supply.

Notes

Please use this space for any notes you or your installer may have regarding the installation / plumbing of this product.

At Bristan, we want to make things as easy as possible for our customers. That's why we offer solid guarantees on all our products, effective from the date of purchase, to give you peace of mind.

To start your free guarantee simply scan the QR code and register your product. Alternatively visit www.bristan.com/register.

For any other queries, please call our Customer Service on 0330 026 6273 where our expert team of advisors will be able to offer you any help and advice.

For full guarantee terms and conditions visit www.bristan.com/guarantees.



We Know & We Care