

---

# BRISTAN

---

## Installation Instructions and User Guide

Infrared Temperature Control  
Automatic Basin Spout

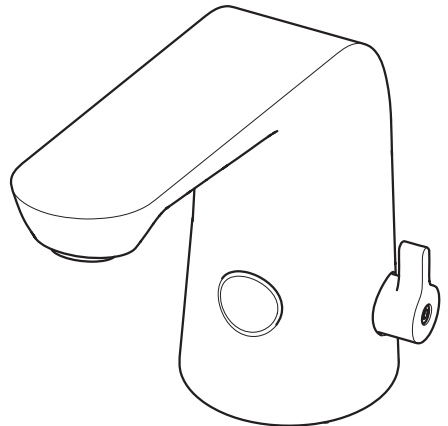

### Models Covered:

IRBS4-CP, IRBS4-BN

**Please keep this booklet for future  
reference.**

Installer, when you have read these  
instructions please ensure you leave  
them with the user.

# Contents

Thank you for choosing Bristan, the UK's leading showers and taps expert.

Your Bristan basin spout has a non-touch control which uses infrared sensing technology to detect human presence. Once detected, the spout instantly dispenses water and automatically stops once the user moves their hands away to eliminate unnecessary water wastage, whilst creating a more hygienic washroom solution.

All products manufactured and supplied by Bristan are safe and comply to legislative requirements. Providing they are installed correctly and receive regular maintenance in accordance with these instructions your user experience will not be affected.

For a safe and successful installation these instructions should be used as guidance, thereafter they should be left with the user.

## Contents

• Important Safety Information	<b>3</b>
• Specification	<b>4</b>
• Product Features	<b>5</b>
• Dimensions (mm)	<b>5</b>
• Installation Requirements	<b>6</b>
• General Installation	<b>7</b>
• Installation - Electrical Connections	<b>8-9</b>
• Installation - Water Connections	<b>9</b>
• Operation	<b>10</b>
• Maintenance	<b>11</b>
• Troubleshooting	<b>12-13</b>
• Notes	<b>14-15</b>

# Important Safety Information

- **Please read these instructions thoroughly and retain for future use.**

- All products manufactured and supplied by Bristan are safe provided they are installed, used correctly and receive regular maintenance in accordance with these instructions.

- **If you are in any doubt about your ability to install this product safely you must employ the services of an experienced qualified plumber/electrically qualified person.**



- **Warning:** Do not operate the product if you suspect it is frozen. Do not site the product where it might be subjected to freezing conditions.

- These fittings need to be installed in accordance with, and meet the requirements of the Water Supply (Water Fittings) Regulations 1999 and current byelaws.

- Remove all packaging and check the contents for damage before starting installation

- Before starting any installation please consider the following: before drilling into walls, check that there are no hidden electrical wires, cables or water supply pipes. This can be checked with the aid of an electronic detector.

- If power tools are used do not forget to:
  - Wear eye protection
  - Unplug equipment after use

- Fitting isolating valves to the inlet feeds is required for ease of maintenance.



- **Warning:** Before installing the new spout it is essential that you thoroughly flush through the pipework in order to remove any remaining swarf, solder, etc. Failure to carry out this procedure could cause problems or damage to the workings of the spout.

- This product **must** not be modified in any way as this will invalidate the guarantee.



# Specification

**Operating Pressure Range:**

Min. 1.0 Bar - Max. 5.0 Bar

**Maximum Static Pressure:** 10 Bar

**Inlet Water Supply Temperature Range:**

5°C - 74°C

**Power Supply:** AC: 220V-240V; 50/60HZ

DC: 6V

(4 x AA alkaline batteries - Not Supplied)

**Power Consumption:** Static  $\leq 0.2mW$

Active:  $\leq 2W$

**Sensing Range:** 0-18cm



**Note:** Do not site the tap in areas with highly reflective surfaces as this may affect the performance of the tap.

Also ensure that the product is at least 360mm away from reflective surfaces to prevent the tap from automatically switching on and off.

**Self-close Override Time:** 30 seconds

$\pm 5$  seconds

Recommended Usage			
Domestic	✓	Heavy Commercial	✓
Light Commercial	✓	Health Care	✗

This product has been tested to meet the requirements of the Water Regulations Advisory Scheme (WRAS) and satisfies the requirements of the Water Supply (Water Fittings) Regulations 1999 and current byelaws.

BS 6700 recommends the temperature of stored water should never exceed 65°C. A stored water temperature of 60°C is considered sufficient to meet all normal requirements and will minimise the build up of limescale in hard water areas.

This product should be installed in compliance with the current Water Regulations.

If in doubt, contact a registered plumber or your Local Water Authority or the Secretary of The Institute of Plumbing, address as follows;-

The Institute of Plumbing,  
64 Station Lane,  
Hornchurch,  
Essex, RM12 6NB  
Tel:01708 472791

**IMPORTANT**

In order to meet Part G building regulations, an approved thermostatic blending valve is required in order to install this tap correctly.

Please visit our website for more details on our blending valves.

# Product Features

## Water Efficient

When the users hands enter the sensing range, the indicator light in the sensor will illuminate. Water will flow out immediately until the user draws their hands back from the sensor.

The water will automatically stop after a maximum of 30 seconds  $\pm$  5 seconds to avoid wasting water. If more water is required wait 3 seconds and then place hands back in the sensing range.

## Temperature Control

Manual temperature control lever allows users to set preferred temperature.

## More Hygienic

The proximity sensor removes the need to touch the spout body, reducing the spread of germs and reducing the chance of cross infection.

## Battery Override

In the event of a power failure, the product will automatically switch to battery operated mode to ensure the spout continues to function. The tap can also operate on the battery alone if no mains power source is available.

## Low Battery Warning

When the batteries run low and the power falls below 3.9V the sensor light will flicker to indicate the batteries are running low and need replacing.

When the batteries are exhausted the sensor light will not light up.

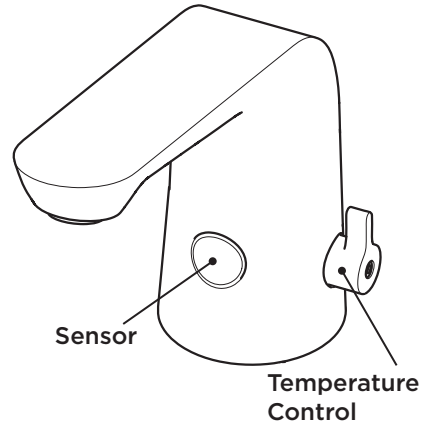

## Dimensions (mm)

IRBS4-BN/CP

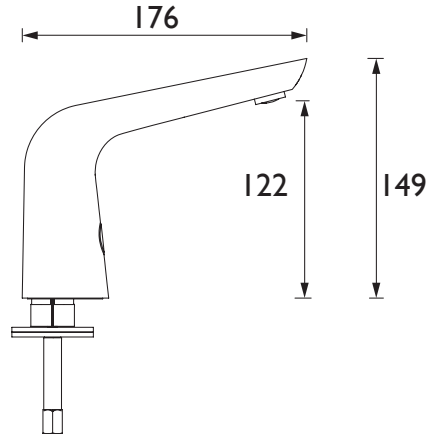

# Installation Requirements

## Electrical Connections

**Regulations:** The electrical installation must be carried out in accordance with the national electrical regulations and installed by a qualified person.

**Safety:** In the interests of electrical safety a 30 mA residual current device (R.C.D not supplied) should be installed in the supply circuit. This may be part of a consumer unit or a separate unit.

Before starting work on the electrical supply ensure the power supply is isolated.

**DO NOT** allow the supply cord to contact hot surfaces. The cord should be safely routed and secured by cable clips.

**Connections:** The power supply box must be permanently connected to the fixed wiring of the mains supply using the factory fitted supply cord, via a switched fused spur off the ring main.

The wires in the mains lead are coloured in accordance with the following code:

Blue: Neutral

Brown: Live

As the colours of the wires in the mains lead of this appliance may not correspond with the coloured markings identifying the terminals in your connection unit proceed as follows;-

The wire which is coloured blue must be connected to the terminal which is marked with the letter 'N' or is coloured black.

The wire which is coloured brown must be connected to the terminal which is marked with the letter 'L' or is coloured red.

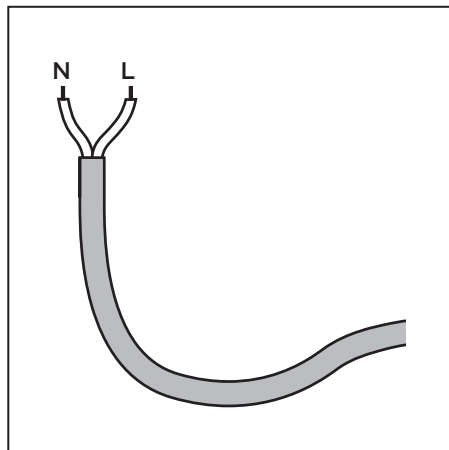

**Fuse:** This following fuse size should be used.

Model	Fuse Size (AMPS)
IRBS4-CP	3
IRBS4-BN	3

## Supply Cord Replacement

If the supply cord is damaged, it must be replaced by a genuine Bristan supply cord. Contact Bristan Customer Services on 0330 026 6273 to request new spare parts.

# General Installation

## 1. Fit The Spout

Fit the spout to the sink / work surface ensuring the sensor cable is threaded through the hole in the sink / work surface.

Also ensure that the product is at least 360mm away from reflective surfaces to prevent the tap from automatically switching on and off.

## 2. Secure Spout to Sink / Work Surface

Thread the rubber washer and metal washer onto the fixing rod up to the underside of the sink / work surface.

Secure the spout in place by screwing the fixing nut onto the fixing rod.

Tighten the fixing nut using a suitable spanner.

## 3. Connect Sensor Cable

See 'Electrical Connections' installation.

## 4. Connect Water Supplies

See 'Water Connections' installation.

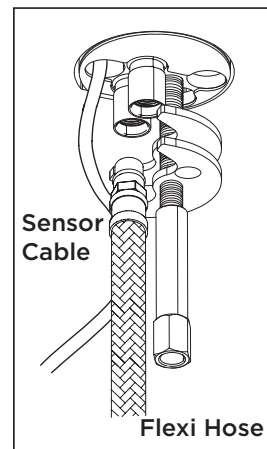
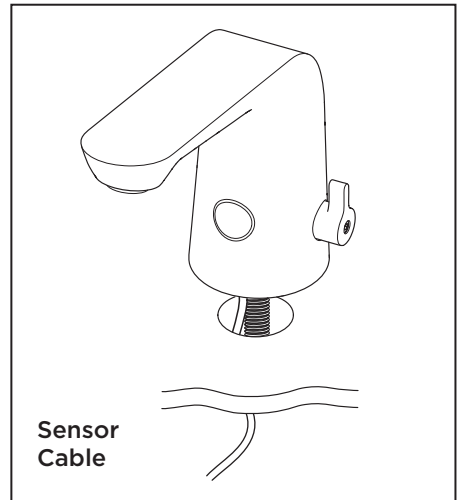

# Installation - Electrical Connections

## Connect Power Supply Cable



Before starting any electrical work ensure the power supply is isolated.

Wire the electrical power cable into a switched fused spur off the ring main.

The blue wire should be wired to the neutral connection and the brown wire should be connected to the live connection.

**Note:** For full electrical requirements see 'Electrical Connections' in 'Installation Requirements' section.

**Important:** This product must be permanently connected to the fixed wiring of the mains supply using the factory supplied power cable.

## Power/ Sensor Cable Connection

Connect the transformer cable to the sensor and battery box connectors.

## Attach The Wall Bracket

Attach the wall bracket to the wall by using screws and wall plugs provided. Place the battery box into the battery housing bracket and attach to the wall bracket.

## Setting Up The Sensor

Once the tap has been installed, disconnect the sensor connector from the transformer cable for 30 seconds, Reconnect and put the hand at the required position in front of the sensor until the light stops flashing.

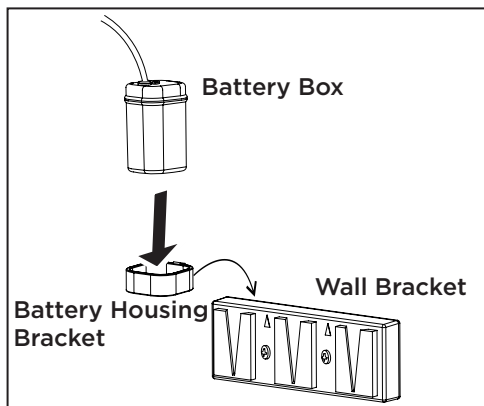
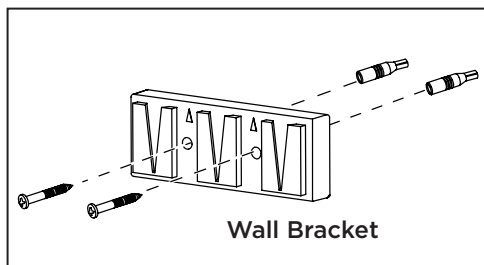
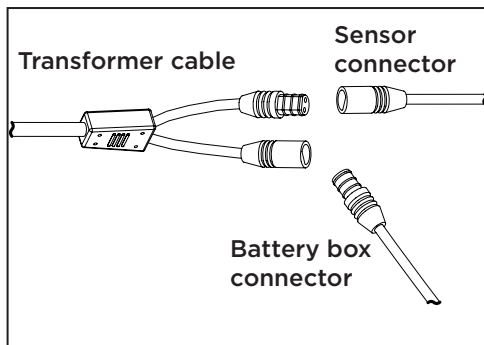



# Installation - Electrical Connections

## Inserting Batteries

Your infrared spout is supplied with a back up battery pack. In the event of a power failure the batteries will override the mains power supply to ensure the spout continues to function.

### 1. Insert Batteries

Insert 4 x AA batteries into the battery box ensuring they are inserted the correct way.

**Note:** Only use 1.5V AA (LR6) Alkaline batteries (preferably => 2000mAh for good battery life).

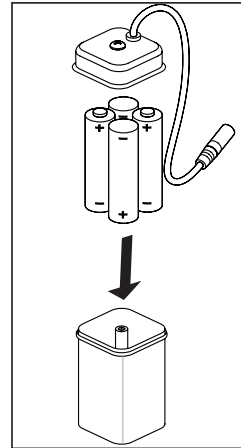

# Installation - Water Connections

## Flexible Tails

Care must be taken when connecting the flexible connection hose from the power supply box to the spout to ensure it does not bend sharply and kink or twist. See below for recommended ways to fit the flexible tails.

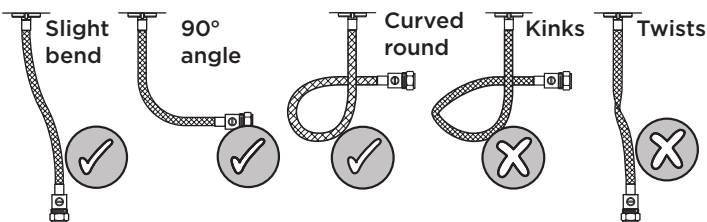

### IMPORTANT

Failure to follow these guidelines may result in poor performance and damage to the flexible tails.



Before connecting the water supplies to the spout, flush through the pipework to ensure removal of debris.

Turn off the mains water supply and close any isolating valves. Screw the flexible tails into the bottom of the spout, ensuring it is **tightened fully by hand only**.

Connect the flexible tails to the hot and cold water supplies. Turn on the mains water supply letting the water flow for a few minutes. Check all joints and connections for any leaks.

# Operation

## Using the Automatic Basin Spout

Place the users hands under the spout within the sensing range. Once the users hands have been detected water will flow constantly until the hands are removed.

After  $30 \pm 5$  seconds the water will stop flowing.

If the user requires more water remove hands from the sensing range and wait 3 seconds, then place the hands back into the sensing range and the water will flow again.

**Note:** The sensing range for all models is 30-32cm from the sensor.

## Temperature Control

Manual temperature control lever allows users to set preferred temperature.

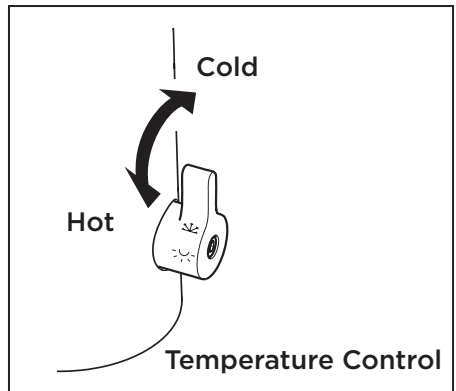
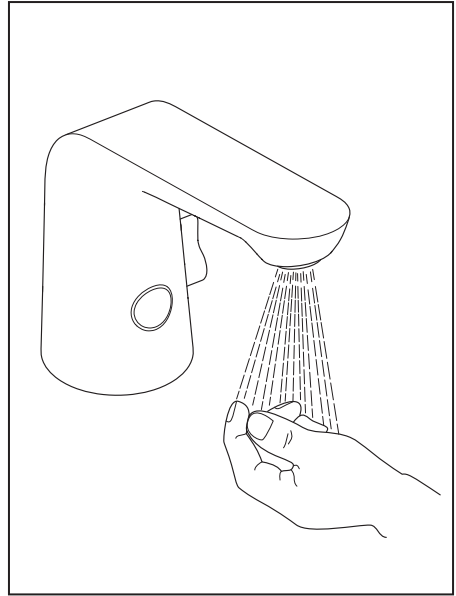

# Maintenance

## General Cleaning

Your fitting has a high quality finish and should be treated with care to preserve the visible surfaces. All surfaces will wear if not cleaned correctly, the only safe way to clean your mixer is to wipe with a soft damp cloth. Stains can be removed using washing up liquid. All bath cleaning powders and liquids will damage the surface of your fitting, even the non-scratch cleaners.

**Note:** Never use abrasive detergents or disinfectants or those containing alcohol, hydrochloric acid or phosphoric acid.

## Cleaning the Inlet Filter

Before carrying out any maintenance, turn off the mains water supply and close any isolating valves.

In hard water area it may be necessary to regularly clean the inlet filter to maintain optimum performance of the infrared spout.

Remove the flexi tails from the inlet water supply and remove the inlet filter. Run under cold water to remove any build up of limescale and debris. Replace the filter and re-attach the flexi tails to the inlet water supply.

## Disposal and Recycling

### End of Product Life

When this appliance has reached the end of its serviceable life, it should be disposed of in a safe manner, in accordance with current local authority recycling, or waste disposal policy.

### Battery Disposal

Spent batteries should not be disposed of with normal household waste. Contact your local authority for information on waste disposal and recycling.

This symbol on the product or packaging indicates that this product should not be disposed of with your other household waste. Instead, it is your responsibility to dispose of your waste equipment by handing it over to a designated collection point for the recycling of waste electrical and electronic equipment. The separate collection and recycling of your waste equipment at the time of disposal will help to conserve natural resources and ensure that it is recycled in a manner that protects human health and the environment.



For more information about where you can drop off your waste equipment for recycling, please contact your local council office, your household waste disposal service or the shop where you purchased the product.

# Troubleshooting

Symptom	Cause	Remedy
<b>Spout does not operate e.g no water flow.</b>	Sensor cable not connected.	Check that the sensor cable is connected. If not connected, connect sensor cable. Refer to the 'Electrical Connections' section.
	Water supply not turned on.	Turn on water supply and open any isolation/service valves.
	Solenoid valve not opening.	<b>Contact Bristan Customer Services.</b>
	No mains electrical power to the power supply box.	Connect power supply cable. Refer to the 'Electrical Connections' section.
	Blockage in water supply pipework.	Remove pipework and flush to remove any debris. Remove inlet filter and clean under running water.
	Inlet water supply pressure too low.	Refer to 'Specification' section for working pressures.
<b>No power to the power supply box.</b>	No Mains power to the power supply box.	Connect power supply cable. Refer to the 'Electrical Connections' section.
	Mains power supply failed and no batteries fitted or batteries low.	Check mains power supply. Insert/change batteries. Refer to 'Installation - Inserting batteries' section.
<b>Flow of water too low</b>	Inlet filter is partially blocked.	Clean inlet filter. Refer to 'Maintenance' section.
	Partially closed stop or service valve in water supply pipework.	Open stop or service valve.
	Inlet water supply pressure too low.	Adjust inlet water pressure accordingly. Refer to the 'Specification' section.

# Troubleshooting

Symptom	Cause	Remedy
<b>Flow of water too high.</b>	Inlet water supply pressure too high.	Adjust inlet water pressure accordingly. Refer to the 'Specification' section.
<b>Spout runs randomly without a user present.</b>	Object in the sensing range. Reflective surfaces, i.e. High Visibility jacket/clothing activate the sensor.	Ensure the sensing range is clear. Ensure that the product is at least 360mm from reflective surfaces.
<b>Sensor light not working.</b>	Sensor light faulty.	<b>Contact Bristan Customer Services.</b>
	Circuit board faulty or has been allowed to get wet.	
	Batteries are exhausted.	Replace batteries.
<b>Short cycles of batteries.</b>	Incorrect batteries fitted.	Replace batteries. Ensure batteries are 1.5V AA (LR6) Alkaline batteries (preferably =>2000mAh) for good battery life.
<b>Infrared sensor flickering.</b>	Batteries running low.	Replace batteries. Ensure batteries are 1.5V AA (LR6) Alkaline batteries (preferably =>2000mAh) for good battery life.

# Notes

# Notes

---

**Issue: D4**

**Part Number: FI IRBS4**

# **BRISTAN**

## **Bristan Group Ltd.**

**UK:** Bristan Group, B78 1SG.

**EU:** Masco Europe S.à.r.l.  
14 Rue Strachen  
6933 Mensdorf  
Luxembourg

**Customer Service:** +44330 026 6273

**Web:** [www.bristan.com](http://www.bristan.com)

**Email:** [enquire@bristan.com](mailto:enquire@bristan.com)

## **A Masco Company**

At Bristan, we want to make things as easy as possible for our customers. That's why we offer solid guarantees on all our products, effective from the date of purchase, to give you peace of mind. To start your free guarantee simply scan the QR code and register your product. Alternatively visit [www.bristan.com/register](http://www.bristan.com/register).

For any other queries, please call our Customer Service on 0330 026 6273 where our expert team of advisors will be able to offer you any help and advice.

For full guarantee terms and conditions visit [www.bristan.com/service-centre/guarantees](http://www.bristan.com/service-centre/guarantees).



*We Know & We Care*