

MLB SNK BLK

MELBA Tap Range Melba Sink Mixer Black

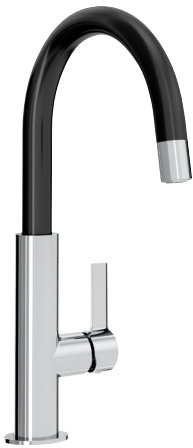

Specification	
Style:	Contemporary
Product Type:	Kitchen Taps
Finish/Colour:	Black & Chrome
Main Construction Material:	Brass
Mount Type:	Deck Mounted
Handle Type:	Lever
Connection Inlet:	1/2" BSP Flexible Tails
Number of Tap Holes Required:	1
Valve/Cartridge Type:	25mm Cartridge
Plumbing System Suitability	High Pressure Systems Only
Working Pressure Range:	Min 1.0 Bar, Max 5.0 Bar
Maximum Hot Water Temperature: °c	65
Maximum Dynamic Pressure: (bar)	5
Maximum Static Pressure: (bar)	10
Flow Type:	Single Flow
Flow Rate: (l/min @ 3 bar)	12.9
Connection Outlet:	M22 Flow Straightener
Isolation Included:	No

Features:

- Metal fixing nut
- Ceramic Cartridge for added durability and ease of use
- Flexi Tails
- Metal handle
- Chrome plated to BS EN 248

Product Certifications:

WRAS Certificate No: 1609025
WRAS Expiry Date: 30/09/2021



Also available from the
Kitchen Tap Range is:

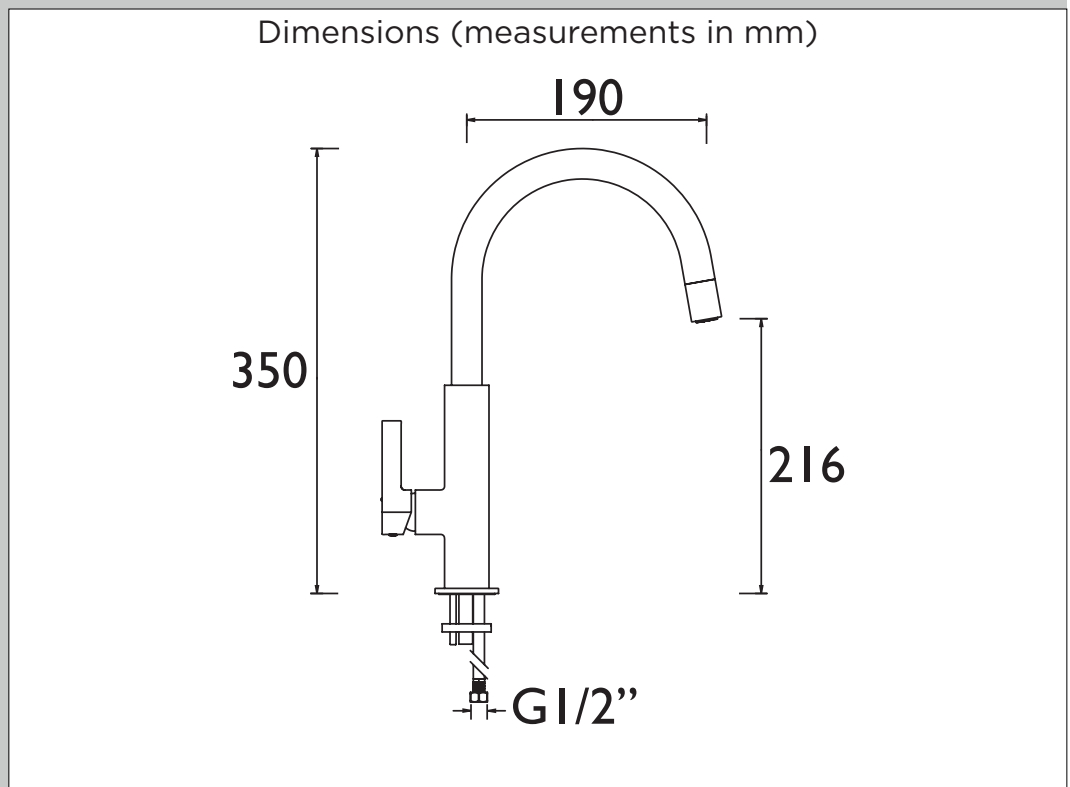

Flow Rates (l/min)					
System Pressure (bar)	1	2	3	4	5
MLB SNK BLK	7.4	10.6	12.9	15.3	17.1

TECHNICAL
DATA
SHEET



BRISTAN
TAPS & SHOWERS

D3