BRISTAN

Installation Instructions and User Guide

Solo T3 Thermostatic Basin Tap

Models Covered:

SOLO2-T3SL, SOLO2-T3LL

**Please keep this booklet for future
reference.**

**Installer, when you have read these
instructions please ensure you leave
them with the user.**

Contents

Thank you for choosing Bristan, the UK's leading showers and taps expert.

Your Bristan mixer tap is a thermostatic mixer incorporating a wax capsule thermostat to ensure constant temperatures. These instructions are for your guidance to a safe and successful installation and should be left with the user. All products manufactured and supplied by Bristan are safe providing they are installed correctly and receive regular maintenance in accordance with these instructions.

Contents

• Important Safety Information	3
• Specification	4
• Prior to Installation	5
• Installation Requirements	6-8
• Installation	9
• General Cleaning	10
• Maintenance	10
• Operation	10
• Maintenance	11-13
• Troubleshooting	14-15

Important Safety Information

Please read these instructions thoroughly and retain for future use.

All products manufactured and supplied by Bristan are safe to use provided that they are installed, operated and receive regular maintenance in accordance with these instructions.

This product has been tested to the TMV Type 3 scheme for use in Healthcare and Commercial situations and performs to the requirements of NHS Specification D08. It also satisfies the requirements of the Water Supply (Water Fittings) Regulations 1999 and current by-laws. For full Installation Requirements & Notes (IRN) please visit wras.co.uk/directory.

To ensure the product is installed in compliance to the TMV Type 3 and D08 standards, please refer to the TMV Manual provided separately with this product. **Failure to do so may mean that the tap is no longer compliant.**

Isolation valves must be fitted to the inlet water supplies to ensure ease of future maintenance. Before installing this product the water supply must be thoroughly flushed in order to remove any swarf, solder etc. Full access must be made available for future maintenance/servicing purposes.

Before drilling into walls, check that there are no hidden electrical wires, cables or water supply pipes. This can be checked with the aid of an electronic detector.



If power tools are used do not forget to:

- Wear eye protection
- Unplug equipment after use



Warning: Before installing the new mixer valve it is essential that you thoroughly flush through the pipework in order to remove any remaining swarf, solder, etc. Failure to carry out this procedure could cause problems or damage to the workings of the mixer tap.

If you are in any doubt about your ability to install this product safely you must employ the services of an experienced qualified plumber. If in doubt, contact a registered plumber, your Local Water Authority or the Secretary of the Institute of Plumbing, address as follows:-

The Institute of Plumbing,
64 Station Lane,
Hornchurch,
Essex,
RM12 6NB, Tel: 01708 472791

Specification

Inlet Connections: 15mm compression copper connecting pipes.

Operating Pressure Range: Min. 0.2 Bar - Max. 5.0 Bar - Maximum recommended imbalance between hot and cold supply should not exceed a ratio of 5:1.

Maximum Static Pressure: 10 Bar

Maximum Outlet Temperature: Factory pre-set to 41°C

(can be re-set to suit site conditions). If the temperature is re-set to suit different site conditions the mixer will work adequately, however the TMV Type 3 scheme will not apply.

TMV Type 3 Designation: HP-WE; LP-WE

Supply Requirements:

Minimum cold water supply temperature: 5°C.

Maximum cold water supply temperature: 25°C.

Maximum hot water supply temperature: 80°C.

(a maximum hot water supply temperature of 60 - 65°C is recommended for ablutionary purposes)

If the fitting is installed at low pressure (tank fed), then the minimum distance from the outlet to the underside of the cold tank should be at least 2 metres to ensure adequate performance. Nominally equal (balanced) inlet supply pressures are recommended for optimum performance with mixer taps.

Note: The inlet hot water temperature must be at least 10°C above the required blend temperature (eg. mixer temperature 41°C: minimum hot supply 51°C).

Flow Regulators:

This product is supplied fitted with a yellow 5 l/min (Hot) and an Olive 2 l/min (Cold) flow regulator which should remain fitted for both high and low pressure systems.

If the flow regulators are replaced, they **must** be fitted as below:

Yellow 5 l/min - Hot Outlet

Olive 2 l/min - Cold Outlet



Warning: This tap is **not suitable** to deliver potable/ drinking water.

Prior to Installation

Flow Straightener.

This mixer tap is supplied with a choice of laminar or open outlet flow straighteners.

Both flow straighteners are supplied loose in the box, allowing the installation to be made in line with different site conditions and user preference.

To Fit the Flow Straightener

Insert the chosen flow straightener into the casing, ensuring the sealing washer is placed on top of the flow straightener.

Using a suitable spanner tighten the casing into the spout outlet.

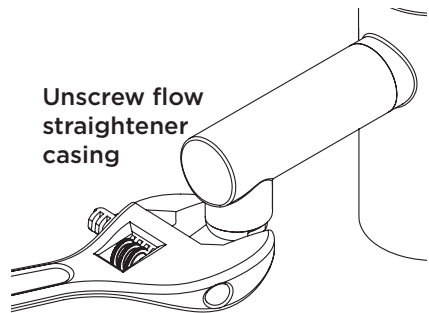
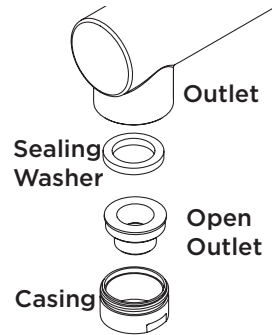
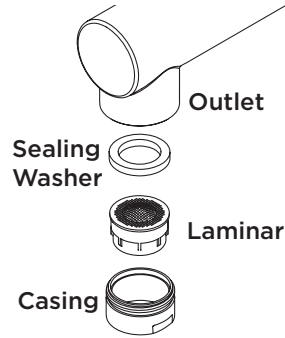

Installation Requirements

Instantaneous Water Heater

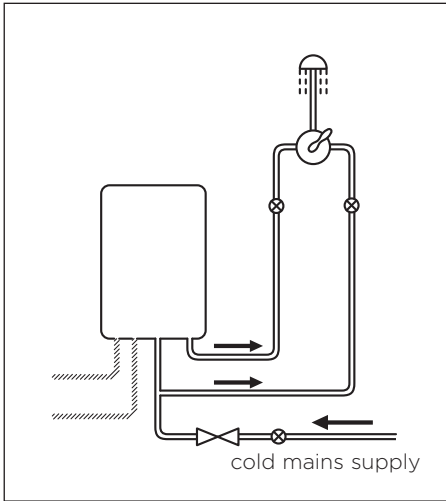

Invented System

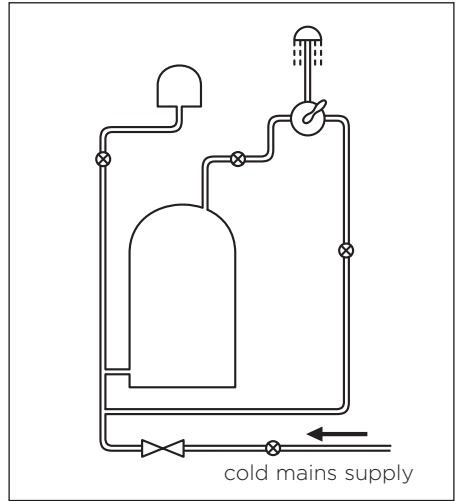

Pumped System

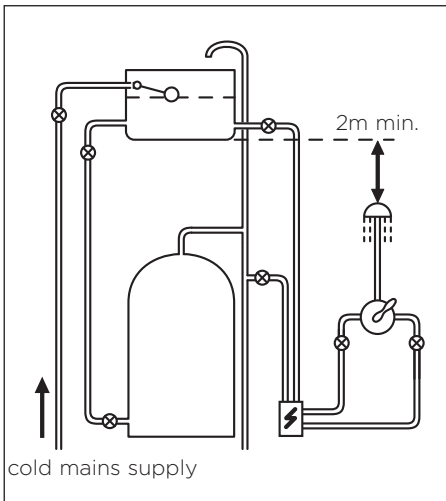

Pumped System (with Essex flange)

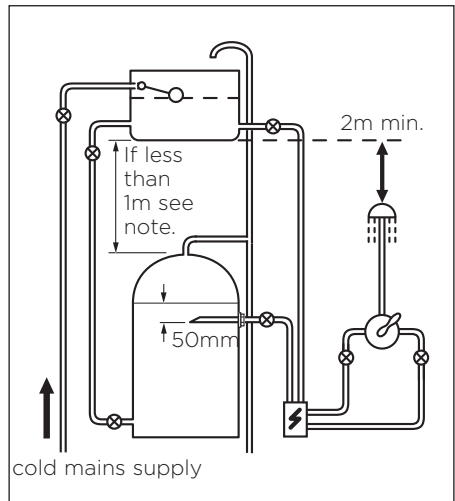

Key:  Isolating Valve  Reducing Valve  Mixer Tap  Pump  Essex Flange

Installation Requirements

This fitting needs to be installed in accordance with the following Installation Requirements and Notes (IRN) to ensure they meet the requirements of the Water Supply (Water Fittings) Regulations 1999 and the Scottish Byelaws 2004.

IRN R001: See text of entry for Installation Requirements or Notes.

IRN R040 - Schedule 2-15 (1): The fitting shall be installed so that its outlet discharges above the spill-over level of any fixed appliance as indicated below:-

For backflow protection in domestic or installations up to, and including, Fluid Category 3.

If the fitting cannot be installed as indicated in the table opposite it shall be installed as either **a** or **b** below:

a: with an approved double check valve assembly or some other no less effective backflow prevention device immediately upstream of the inlet.

b: so that it draws water by gravity only from a cistern, or cylinder having a permanently open vent pipe, and the distributing pipe supplies no other fittings (other than a draining tap) at a lower level.

For backflow protection in premises or installations up to, and including Fluid Category 5.

The vertical distance of the outlet above the spill-over level shall be not less than 20mm or twice the diameter of the inlet pipe to the fitting, which ever is the greater. If the fitting cannot be installed as indicated it shall be installed with a backflow prevention arrangement suitable for the Fluid Category.

Size of tap or combination fitting	Vertical distance of outlet above spill-over level
1. Not exceeding ½"	20mm
2. Exceeding ½" but not exceeding ¾"	25mm
3. Exceeding ¾"	70mm

Installation

1. Screw the fixing rods into the bottom of the fixing base.

Position the fixing base into the hole in the basin ensuring the rubber washer is fitted between the fixing base and the basin.

2. Slide the metal plate onto the threaded rods under the basin and secure the fixing base to the basin by tightening the fixing nuts onto the fixing rods. Ensure the fixing nuts are tightened fully by using a suitable spanner.

3. Screw the copper connecting pipes into the bottom of the fixing base by **hand only (DO NOT OVERTIGHTEN)**.

⚠ Important: Before connecting the copper connecting pipes to the water supply thoroughly flush through the pipework in order to remove any remaining swarf, solder, etc.

Connect the copper connecting pipes to the water supplies. **Do not turn the water supplies on.**

4. Push the mixer body onto the fixing base ensuring the rubber 'O' ring is fitted into the groove in the bottom of the mixer body. Ensure the mixer body is fitted correctly and tighten the grub screws fully to secure the mixer body in position.

5. Turn on both water supplies, operate the handle in both hot and cold positions, letting the water flow for a few minutes to flush through the system.

6. Check all joints and connections for any leaks.

You can now refer to the TMV Manual to Commission the valve.

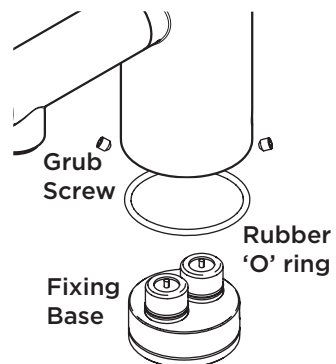
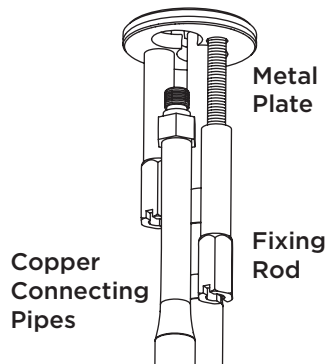
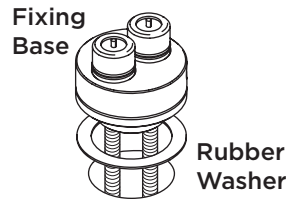

Operation

On / Off and Temperature Control

Turn the lever anti-clockwise to turn on the flow of water.

The water temperature will increase the further the lever is turned.

To decrease the temperature of water turn the lever back clockwise.

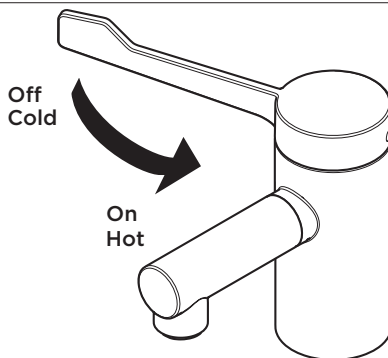

General Cleaning

Bristan products are made from premium materials, with hand polished, electroplated, PVD or EPD finishes.

Your taps or shower should be regularly cleaned with warm water, a mild pH-neutral liquid soap, and polished with a soft cloth. Any residues from soap, toothpaste, shampoos and shower gels can cause blemishes if not rinsed off straight after use.

Household bleaches and cleaners contain harsh chemicals and may damage the surface finish. Avoid using abrasive cloths, scouring pads, scrub sponges, steel wool or anything similar.

Maintenance

Cleaning / Replacement

To assist with your infection control regime, this mixer is fitted with a removable spout which should be periodically removed and cleaned in line with your site risk assessments.

Replacement spouts are available if required in order to minimise down-time for the mixer during this process.

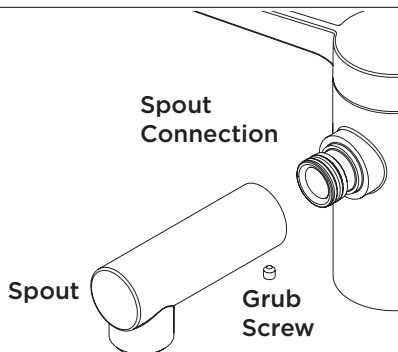

Maintenance

Cartridge Maintenance

We advise that the TMV is regularly serviced in hard water areas to maintain the flow of water.

Isolate both hot and cold water supplies to the mixer tap

1. Remove the control handle lever, remove the cap and undo the screw and remove the lever.
2. Unscrew the cartridge nut anti-clockwise using a 30mm socket and remove the cartridge from the TMV body.
3. Place the cartridge in a bowl and carefully add hot water (just off the boil) and vinegar to de-scale the cartridge. Leave in the solution until the water has cooled and rinse with clean water.
4. Grease the seals with a silicon grease supplied by Bristan (part number: SP-495-0002) and carefully refit the cartridge.
5. Replace the lever handle, tighten the grub screw and push-fit the cap into position.

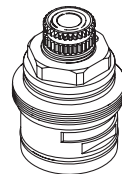
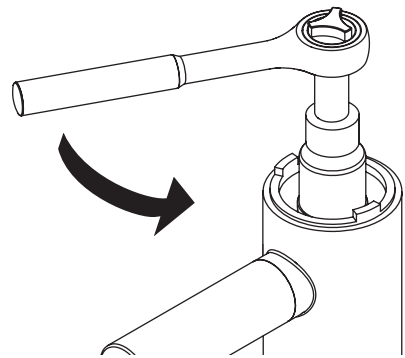
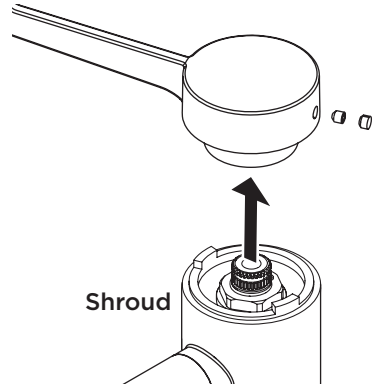

Cartridge

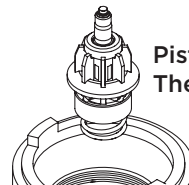

Piston & Thermostat

Maintenance

Non Return Valve Maintenance

Isolate both hot and cold water supplies to the mixer tap.

Loosen both grub screws on either side of the base of the mixer body and pull the mixer body off the fixing base.

Using a suitable set of grips pull the NRV housing out from the fixing base.

Replace the complete NRV housing using a new complete spare housing supplied by Bristan.

Grease both 'O' rings on the housing using a silicon grease and insert the new housing into the fixing base and push firmly into position.

Note: Always replace both housings.

Push the mixer body back onto the fixing base ensuring it is fitted correctly and tighten both grub screws to secure the mixer body in place.

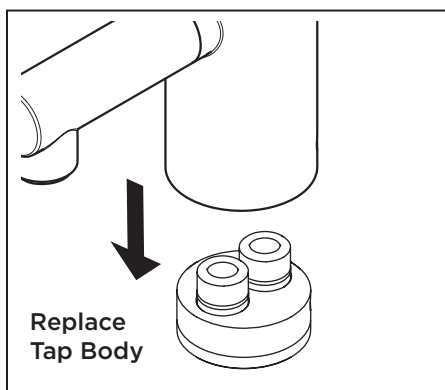
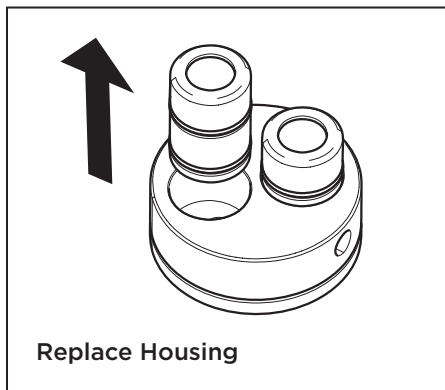
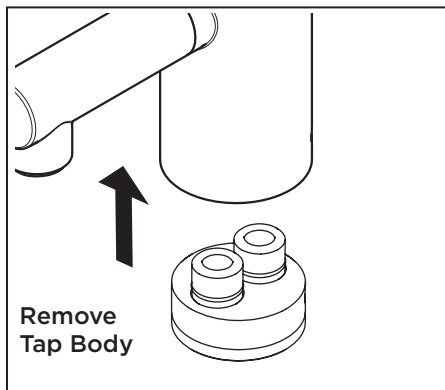

Maintenance

Adjusting the Temperature

The mixer tap has been factory set with equal (balanced) hot and cold water supply pressures with the hot water supply at 65°C.

If your operating conditions are different from those above, the outlet water temperature may differ from the factory setting.

If required the mixer tap can be re-calibrated to suit your own temperature requirements.

Turn the temperature control anti-clockwise (hotter) fully until it stops and check the temperature of the water with a thermometer. If the temperature is not correct, re-calibrate the mixer tap:

1. Turn the flow of water on.
2. Remove the temperature control lever. Remove the cap, undo the grub screw and carefully remove the lever handle.
3. Insert a 2.5mm hexagonal key into the temperature control screw, located at the centre of the cartridge spindle.

Turn clockwise to decrease the temperature and anti-clockwise to increase the temperature.

Check the temperature and adjust until you achieve the required temperature.

4. Replace the handle ensuring it is in the same position as when removed.
5. To finish, tighten the grub screw and push-fit the cover cap into position.

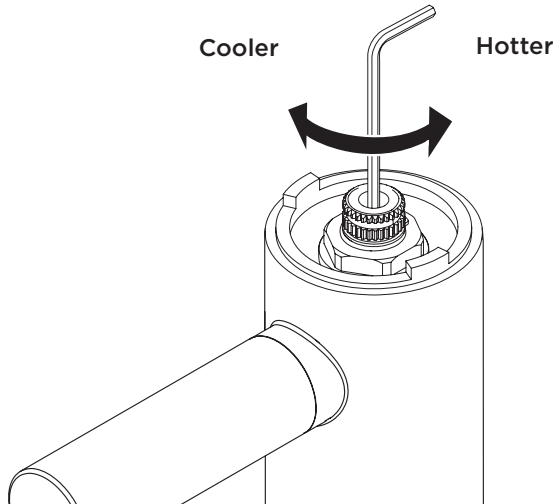

Troubleshooting

Symptom	Cause	Remedy
No flow or low flow rate and / or varying temperatures.	Partially closed stop or service valve in water supply pipework to the mixer tap.	Open stop or service valve.
	Instantaneous water heater cycles on and off as the flow rate or pressure is too low.	Increase water flow rate or pressure through system. Contact the boiler manufacturer.
	Head of water is below the minimum distance required.	Raise the cistern or fit a booster pump.
	Inlet filter is partially blocked.	Clean or replace, flush through pipework before refitting.
	Hot or cold water being drawn off elsewhere causing pressure changes or instantaneous boiler temperature changes.	Do not use other water outlets when using the mixer.
	Make sure the maintained inlet pressures are nominally balanced and sufficient.	Refer to Installation Requirements section (pages 8-11).
	Airlock or partial blockage of the pipework.	Flush through pipework to ensure removal of debris and any airlocks.
	No hot or cold water reaching the mixer tap.	Check hot and cold feeds (the valve will shut down if either the hot or cold supply fails).
Maximum water temperature too hot or cold.	Maximum water temperature set incorrectly.	Reset maximum water temperature. Refer to 'Commissioning' (page 13) Refer to 'Adjusting the Temperature' (page 19).

Troubleshooting

Symptom	Cause	Remedy
Outlet water temperature too hot / cold.	Inlet filter is partially blocked.	Check insert filters for any blockages and clean as necessary.
	Installation conditions outside operating parameters.	Refer to Installation Requirements section (pages 6-9). Service mixer valve as recommended. Refer to Maintenance section (pages 16-19). Refer to Adjusting the Temperature section (page 19).
Water temperature too cold.	Hot water temperature is less than 10°C above the required blend temperature.	Adjust hot water temperature or wait for water to reheat if stored system is used.
	Instantaneous water heater not igniting because water flow rate is too low.	Increase water flow rate through the system. Check cartridge inlet filters and clean or replace. Refer to Maintenance section (page 16-19). Contact the boiler manufacturer.
	Instantaneous water heater not igniting because water pressure is too low.	Increase water pressure through system. Contact the boiler manufacturer.
Only hot or cold water from mixer valve outlet.	Inlet water supplies are reversed (hot to cold supply).	Check the connections are the correct way round. The hot inlet will be to the front of the tap and cold to the rear when the tap is viewed from the front. Rework pipework as necessary.
	Inlet filter is partially blocked.	Clean or replace, flush through pipework before refitting.

Issue: D2.4

Part Number: FI SOLO2

BRISTAN

Bristan Group Ltd.

UK: Bristan Group, B78 1SG.

EU: Masco Europe S.à.r.l.
14 Rue Strachen
6933 Mensdorf
Luxembourg

Customer Service: +44330 026 6273

Web: www.bristan.com

Email: enquire@bristan.com

A Masco Company

At Bristan, we want to make things as easy as possible for our customers. That's why we offer solid guarantees on all our products, effective from the date of purchase, to give you peace of mind. To start your free guarantee simply scan the QR code and register your product. Alternatively visit www.bristan.com/register.

For any other queries, please call our Customer Service on 0330 026 6273 where our expert team of advisors will be able to offer you any help and advice.

For full guarantee terms and conditions visit www.bristan.com/guarantees.

