

BRISTAN

Installation Instructions and User Guide

Sonique, Capri & Acute
Thermostatic Surface
Mounted Mini Shower
Valves

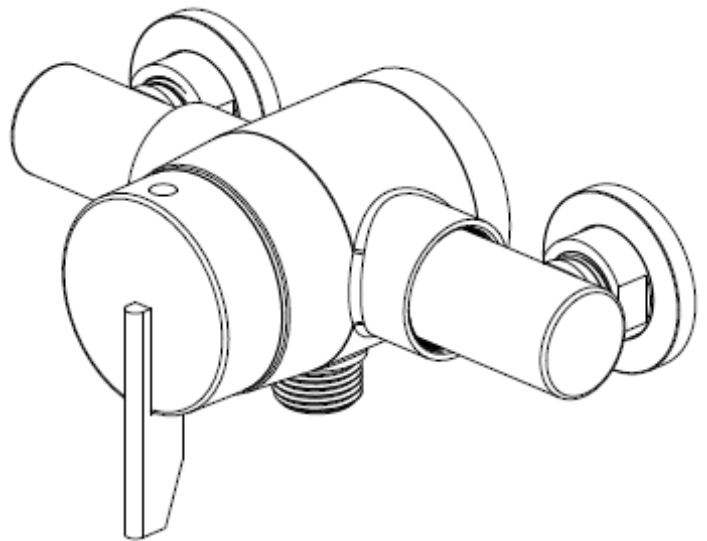

Models covered: SOQ2 SHXAR C,
CAP2 SHXAR C & AE SHXAR C

Please keep this booklet for future
Reference.

Installer, when you have read these
instructions please ensure you leave them
with the user.





Contents

Thank you for choosing Bristan, the UK's leading taps and showers expert. We have designed this product with your enjoyment in mind. To ensure that it works to its full potential, it needs to be fitted correctly. These fitting instructions have been created to give you all of the information you need and, if you need any further help, please do not hesitate to give us a call on 0330 026 6273.

Important Safety Information	3
General Information	4
Product Features	5
Specifications	6
Dimensions	7
Pack Contents	8
Installation Requirements	9-12
Flow Regulators	13-14
Prior to Installation	15
Installation	16-20
Shower Valve.....	16-17
Riser Rail	18-20
Operation	21
Commissioning	22
Maintenance	23-24
In-Service Testing	25-26
Troubleshooting	27-28
Guarantee	29
Notes	30-31

Important Safety Information

- Please read these instructions thoroughly and retain for future use.
- All products manufactured and supplied by Bristan are safe provided they are installed, used correctly and receive regular maintenance in accordance with these instructions.
- **If you are in any doubt about your ability to install this product safely you must employ the services of an experienced qualified plumber.**
- Do not use if the showerhead or shower hose has been damaged or is blocked.
- Do not crush or kink the shower hose, this could damage the hose and cause leaks.
- Remove all packaging and check the components for damage before starting installation.
-  **Warning:** Before starting any installation please consider the following: Prior to drilling into walls, check that there are no hidden electrical wires, cables or water supply pipes. This can be checked with the aid of an electronic detector.
- If power tools are used do not forget to:
 - Wear eye protection
 - Unplug equipment after use
- The fitting of isolating valves is required as close as is practical to the supply inlet feeds of the thermostatic mixing valve.
-  **Warning:** Before installing the new shower valve it is essential that you thoroughly flush through the pipework in order to remove any remaining swarf, solder, etc. Failure to carry out this procedure could cause problems or damage to the workings of the shower valve.
- This product **must not** be modified in any way as this will invalidate the guarantee.

General Information

This product has been tested to the TMV2 scheme which complies with the BS EN 1287:1999 (LP) and BS 1111:1999 (HP) thermostatic mixing valve standards. It also satisfies the requirements of the water supply (water fittings) regulations 1999 and current bylaws.

BS 6700 recommends the temperature of stored water should never exceed 65°C. A stored water temperature of 60°C is considered sufficient to meet all normal requirements and will minimise the build up of lime scale in hard water areas.

Important: Nominally equal (balanced) inlet supply pressures are recommended for optimum performance with mixer showers.

This shower valve should be installed in compliance with the Water Regulations. If in doubt, contact a registered plumber or your Local Water Authority or the Secretary of The Institute of Plumbing, address as follows;-

The Institute of Plumbing,
64 Station Lane,
Hornchurch,
Essex, RM12 6NB
Tel:01708 472791

Guide to designations

HP High Pressure
LP Low Pressure
S Shower

Recommended Usage			
Domestic	✓	Heavy Commercial	✓
Light Commercial	✓	Health Care	✓

Product Features

On/Off and Temperature Control

Turn the control anti-clockwise to turn the shower on and increase the temperature.

Turn the control clockwise to decrease the temperature and to turn the shower off.

Sonique shower valve shown

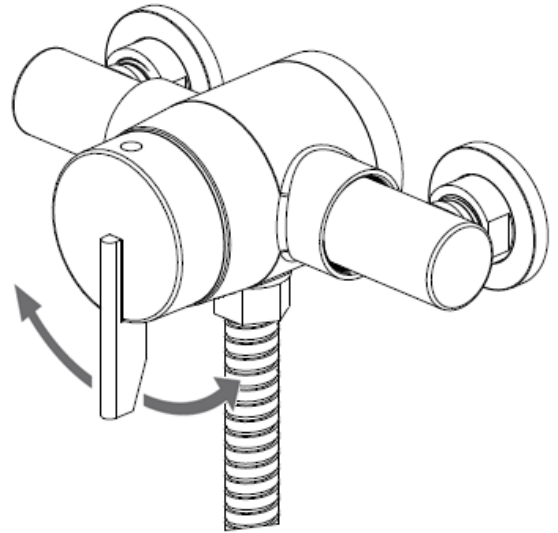

Specifications

Inlet Connections: 15mm compression, with adjustable centres.

Operating Pressure Range: Min: 0.1 bar – Max: 5.0 bar – Maximum recommended imbalance between hot and cold supply should not exceed a ratio of 5:1.

Maximum Static Pressure: 10.0 bar

Maximum Outlet Temperature: Factory pre-set to 41°C (can be re-set to suit site conditions).

Supply Requirements:

Minimum cold water supply temperature: 5°C.

Maximum cold water supply temperature: 25°C.

Maximum hot water supply temperature: 80°C.

(a maximum hot water supply temperature of 60 – 65°C is recommended for ablutionary purposes).

Note: The inlet hot water temperature must be at least 10°C above the required blend temperature (e.g. shower temperature 43°C: minimum hot supply 53°C).

Dimensions (mm's)

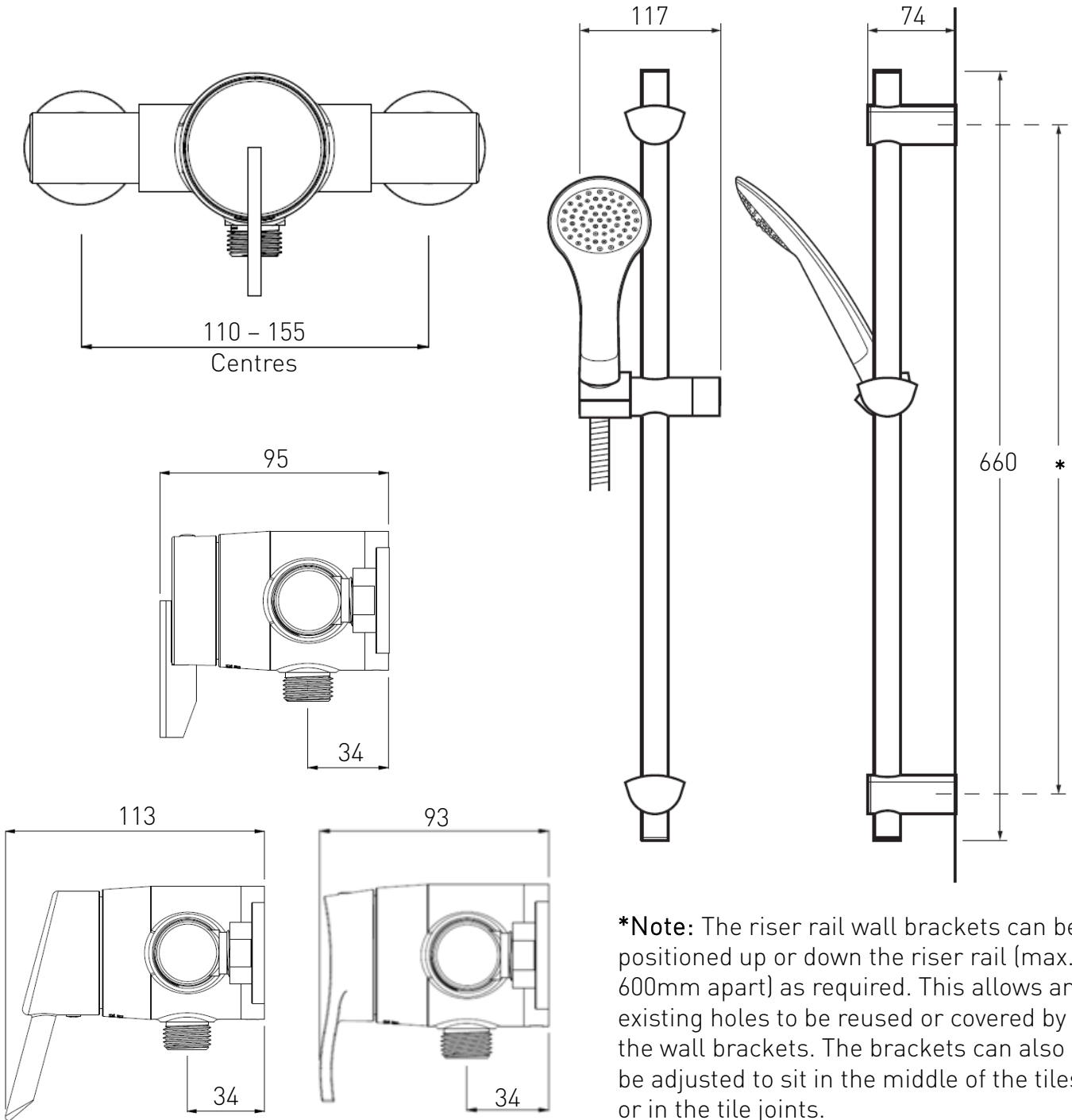

***Note:** The riser rail wall brackets can be positioned up or down the riser rail (max. 600mm apart) as required. This allows any existing holes to be reused or covered by the wall brackets. The brackets can also be adjusted to sit in the middle of the tiles or in the tile joints.

Pack Contents

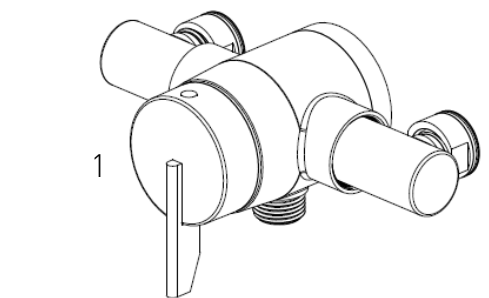

1

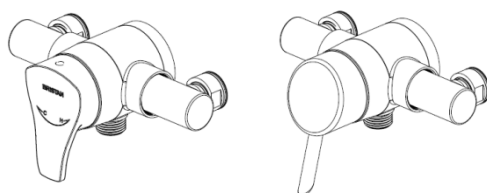

2

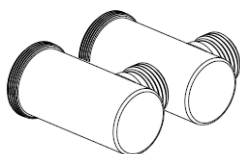

3



4

5



6

7



8



9



10



11

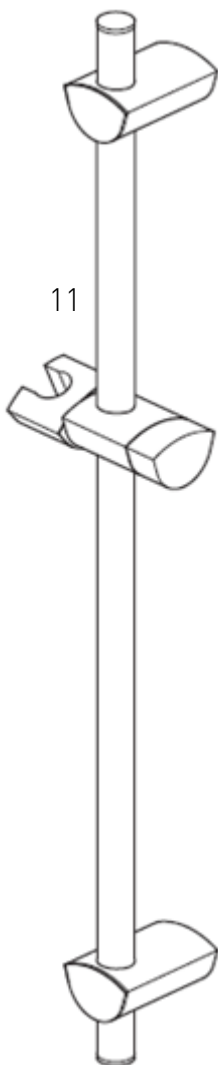

12



- 1 Shower Valve
- 2 Long elbows x2
- 3 Covers x2
- 4 Filters x2 (Pre-fitted)
- 5 Green flow regulator (Pre-fitted)
- 6 Yellow flow regulator (Pre-fitted)
- 7 Backplate fixings x2
- 8 Showerhead (single function)
- 9 Sealing washers x2
- 10 Shower hose
- 11 Riser rail
- 12 Riser rail fixings x4

Installation Requirements

This shower valve must be installed in compliance with current water regulations. If you have any doubts about the water regulation requirements contact your local water services provider or use the services of a professional plumber.

This shower valve is suitable for use with the following water supply systems.

- Gravity Fed Hot and Cold (pressure Balanced)
- Gravity Fed Hot and Mains Cold (differential pressure – see Specification section on page 6.
- Instantaneous Water Heater (combination boiler)
- Unvented System
- Pumped System

Gravity Fed Hot and Cold

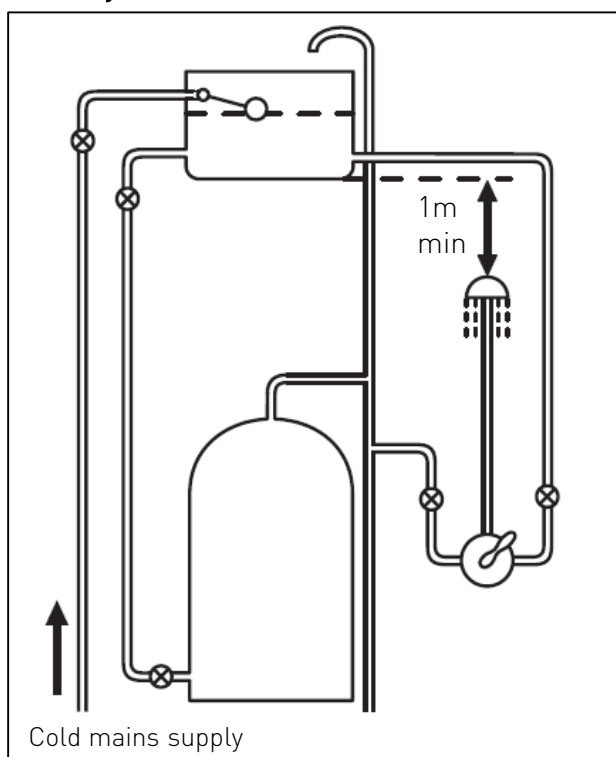

⚠ Important: If you install this shower valve with a gravity fed system, there must be a minimum head (vertical distance) from the underside of the cold water storage tank to the showerhead position of at least 1 metre.

Note: Pumped system (with Essex flange) If you install this shower valve to a pumped gravity fed system where the minimum head (vertical distance) from the underside of the cold water storage tank to the top of the hot water cylinder is less than 1 metre we recommend an Essex flange is used as shown on page 10.

Flushing Pipework

⚠ Important: Before connecting the shower valve (see Installation on pages 16-17), supply pipework **must** be flushed to clear debris before connecting the shower valve. Debris will reduce the performance and life of the shower.

Gravity Fed Hot and Mains Cold

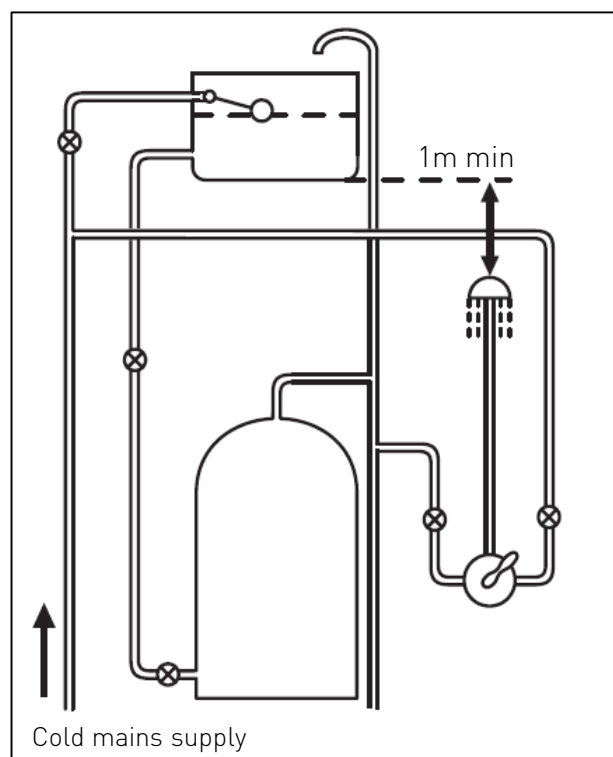

Installation Requirements

Instantaneous Water Heater

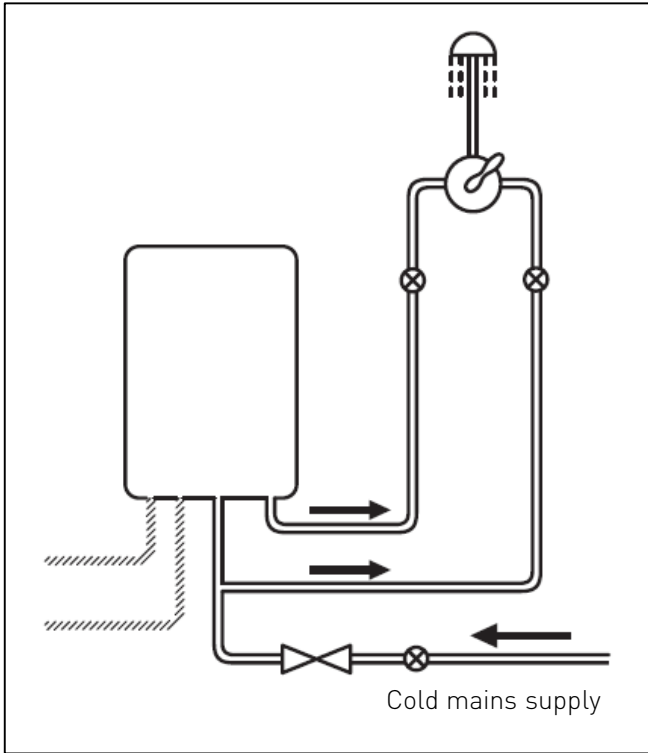

Unvented System

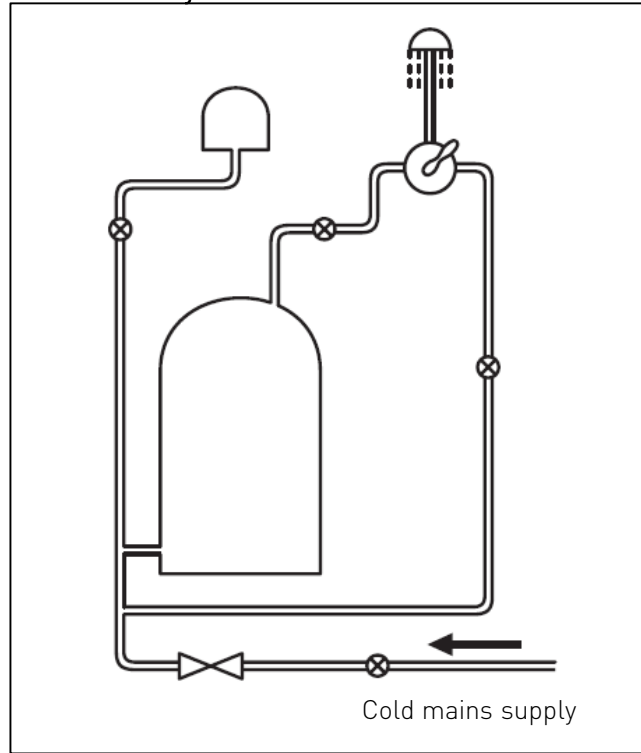

Pumped System

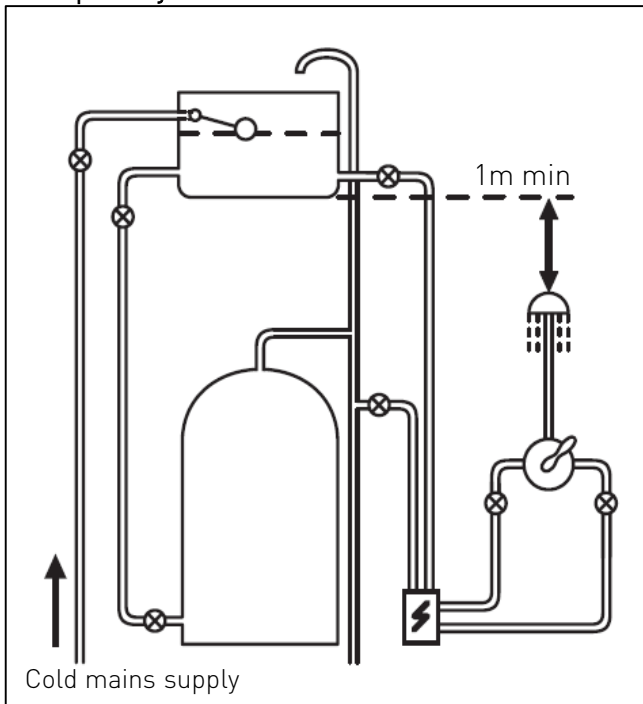

Pumped System (with Essex flange)

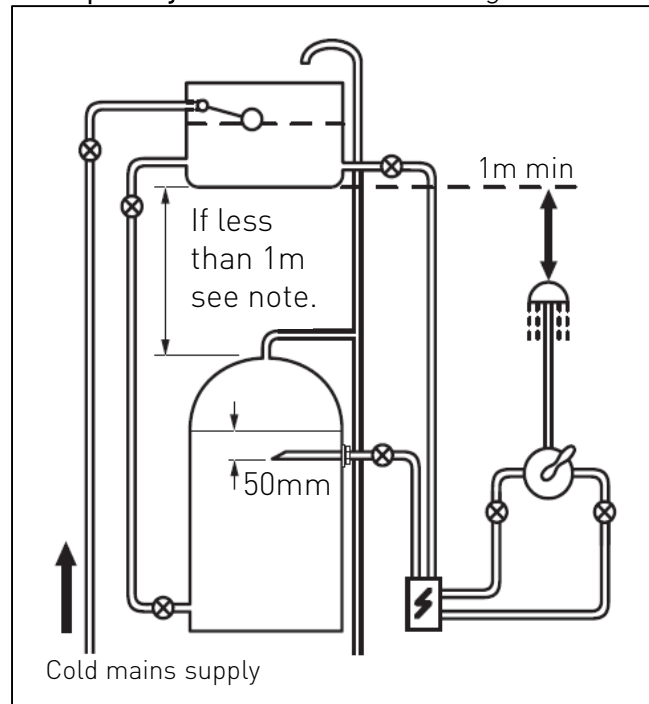

Key:



Isolating Valve



Reducing Valve



Shower Valve



Pump



Essex Flange

Installation Requirements

These fittings need to be installed in accordance with the following Installation Requirements and Notes (IRN) to ensure they meet the requirements of the Water Supply (Water Fittings) Regulations 1999 and the Scottish Byelaws 2004.

IRN R001: See text of entry for Installation Requirements or Notes.

IRN R040 - Schedule 2-15 (1): The fitting shall be installed so that its outlet discharges above the spill-over level of any fixed appliance as indicated below:-

For backflow protection in domestic or installations up to, and including, Fluid Category 3.

If the fitting cannot be installed as indicated in the table opposite it shall be installed as either **a** or **b** below:

a: with an approved double check valve assembly or some other no less effective backflow prevention device immediately upstream of the inlet.

b: so that it draws water by gravity only from a cistern, or cylinder having a permanently open vent pipe, and the distributing pipe supplies no other fitting (other than draining tap) at a lower level.

For backflow protection in premises or installations up to, and including Fluid Category 5.

The vertical distance of the outlet above the spill-over level shall be not less than 20mm or twice the diameter of the inlet pipe to the fitting, whichever is the greater. If the fitting cannot be installed as indicated it shall be installed with a backflow prevention arrangement suitable for the Fluid Category.

Size of tap or combination fitting.	Vertical distance of outlet above spill-over level.
1. Not exceeding 1/2 in	20mm
2. Exceeding 1/2 in but not exceeding 3/4 in	25mm
3. Exceeding 3/4 in	70mm

Installation Requirements

Conditions of use for Type 2 (Thermostatic mixer) valves

	High Pressure	Low Pressure
Maximum Static Pressure (Bar)	10	10
Flow Pressure, Hot & Cold (Bar)	0.5 to 5	0.1 to 1.0
Hot Supply Temperature (°C)	55 to 65	55 to 65
Cold Supply Temperature (°C)	Equal to or less than 25	Equal to or less than 25

Note: Valves operating outside these conditions cannot be guaranteed by the Scheme to operate as Type 2 valves.

The valves designation of use, LP if testes against BS EN 1287, HP if tested against BS EN 1111 and HP & LP if tested against both standards.

If a water supply is fed by gravity then the supply pressure should be verified to ensure the conditions of use are appropriate for the valve.

Minimum supply pressure for LP Tub application is 0.2 bar.

The BuildCert TMV scheme recommends the following set maximum mixed water outlet temperatures for use in all premises:

44°C Bath fill but see notes below

41°C for Showers.

41°C for Washbasins

38°C for Bidets

The mixed water temperatures must never exceed 46°C.

The maximum mixed water temperature can be 2°C above the recommended maximum set outlet temperatures.

Note: 46°C is the maximum mixed water temperature from the bath tap. The maximum temperature takes account of the allowable temperature tolerances inherent in thermostatic mixing valves and temperature losses in metal baths.

 Warning: It is not a safe bathing temperature for adults or children.

Flow Regulators

Selecting Flow Regulators

Supply System		Flow Regulator		
Cold Supply	Hot Supply	Cold	Hot	Comments
0.1 to 1.0bar	0.1 to 1.0bar	No	No	Maximum pressure loss ratio 5:1
1 to 5 bar or pumped	1 to 5 bar or pumped	Green (7 litre)	Yellow (5 litre)	◆ Use arrangement for pumped system
Mains 1.0 – 10 bar	Gravity 0.1 to 0.5 bar	Green (7 litre)	No	
	Gravity Above 0.5 bar	Green (7 litre)	Yellow (5 litre)	
	Unvented Mains / Mains Pressurised			
	Instantaneous Water Gas Heater	Green (7 litre)	* Yellow (5 litre)	
	**Instantaneous Water Electric Heater	Yellow (5 litre)	No	
	Any vented (open outlet) Heater Gas / Electric, e.g. Electric Shower	Do not use with a mixer valve – This would be extremely dangerous		

Flow Regulators

- ◆ Regulators can be fitted if water economy is required.
- * Yellow (5 litre) regulator may not be necessary on some gas water heaters.
- ** ⚠ **Important:** It is a requirement of Instantaneous Electric Heaters that a stable flow of water passes through the heater. This requirement can be satisfied by using a 'flow stabiliser' fitted prior to the heater and should be adjusted to give a temperature of between 45 – 50°C from the heater.

Flow regulators are factory fitted.

Study the table on the previous page and decide which flow regulators are required for your particular situation.

Unscrew both inlet elbows from the valve body and remove flow regulator/s using long nose pliers from the non return valve retainer.

Screw inlet elbows back into the valve body.

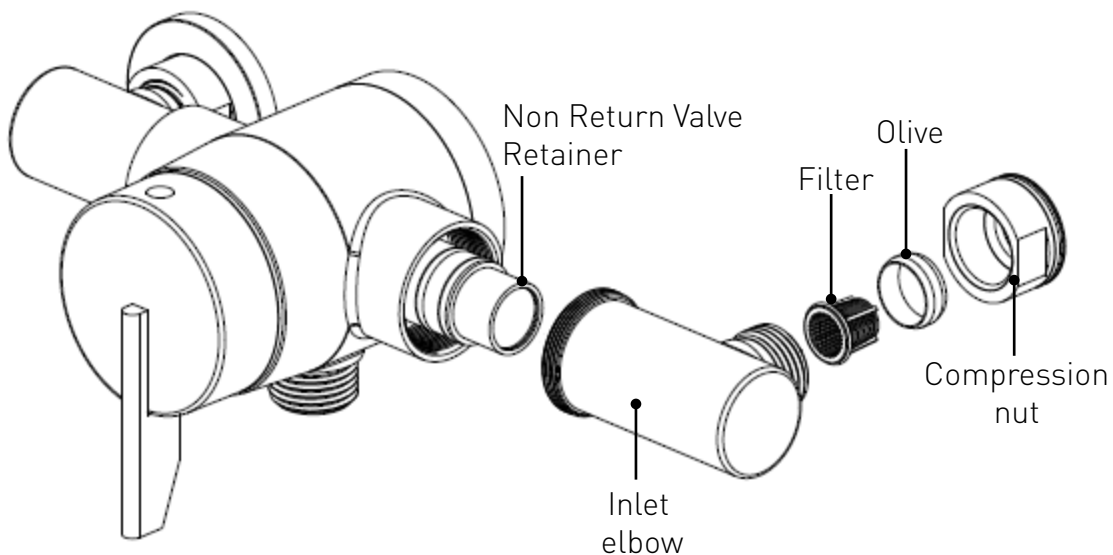
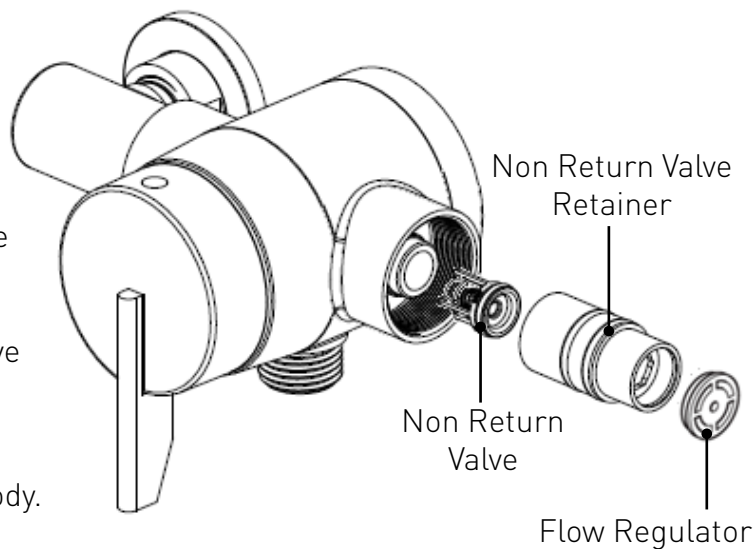

Prior to Installation

This shower valve is supplied with two small and two large elbows to give varying centres.

Note: The shower valve is supplied with the small elbows fitted.

Choose elbow configuration to suit Inlet centres

2 x small elbows – 110-130 centres

2 x large elbows – 136-155

1 small elbow / 1 large elbow – 125-145

All measurements are in millimetres.

To remove the elbows

To remove the elbows from the body unscrew anti-clockwise.

To fit large elbows

Screw the large elbows clockwise into the valve body.

Important: The elbows must have at least two complete turns in the valve body.

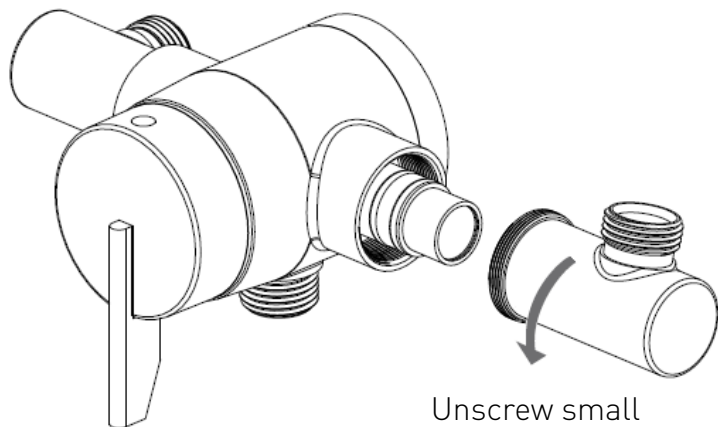

Unscrew small elbow anti-clockwise

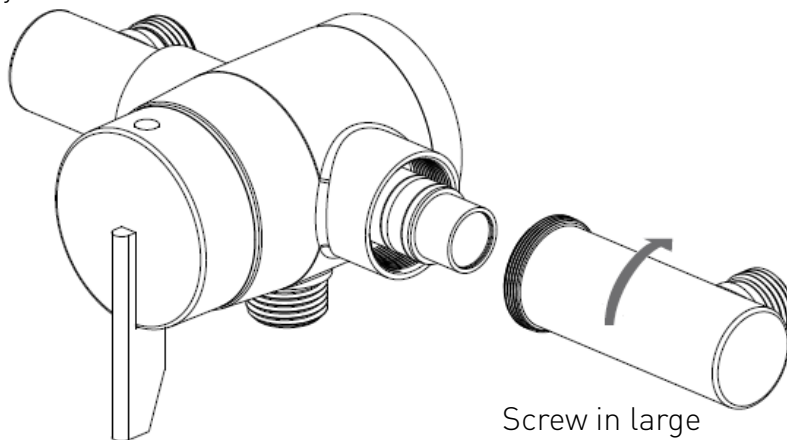

Screw in large elbow clockwise

Shower Valve Installation

Before Installation

Flush through the pipework to ensure removal of debris. Turn off the mains water supply and close any isolating valves.

1. Inlet positions

The shower valve has three inlet positions – top, bottom and rear. Rotate the inlet elbows as required.

With the elbows screwed fully against the valve body it can be unscrewed a maximum of 1.5 turns to allow for lateral tolerance.

Sufficient 15mm diameter supply pipes should protrude through the finished wall surface to fit fully into the shower valve elbows.

2. Attach backplate to wall

Loosen the 'backplate' grub screw on the Back of the valve using a hexagonal key. Use the backplate as a template and mark the centres of the fixing holes onto the wall.

 **Warning:** Please check for any hidden pipes and cables before drilling holes in the wall.

Drill suitable holes and insert the wall plugs. Securely attach the backplate to the wall using the screws provided.

Important: Water supplies to the mixer must be with hot on the left and cold on the right when viewed from the front.

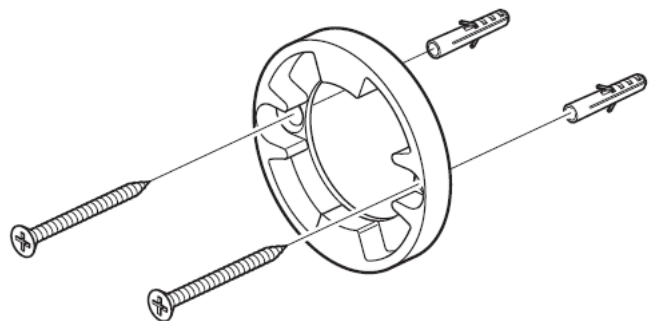
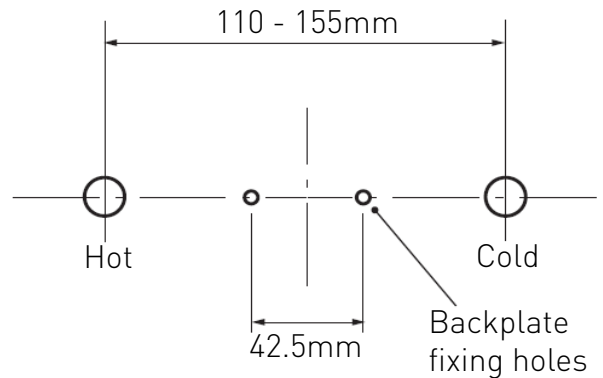

Shower Valve Installation cont.

3. Attach shower valve

Place the shrouds over the water supply pipes. Insert the 15mm hot and cold water supply pipes into the inlet connections and tighten the nuts. Ensure the olives and filter are in place.

Secure the shower valve to the backplate by tightening the backplate grub screw.

Re-attach the shower valve to the backplate by tightening the grub screw.

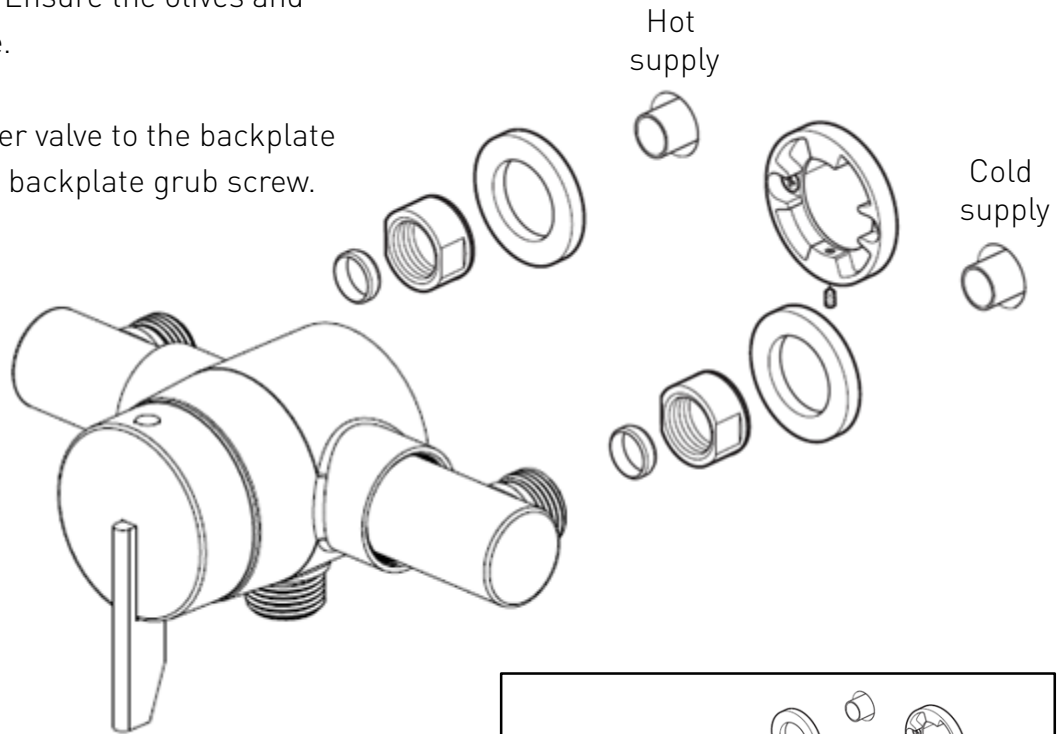

Note: The shower valve inlet positions are shown at the rear as an example.

See pages 18-20 for installation of riser rail and shower hose.

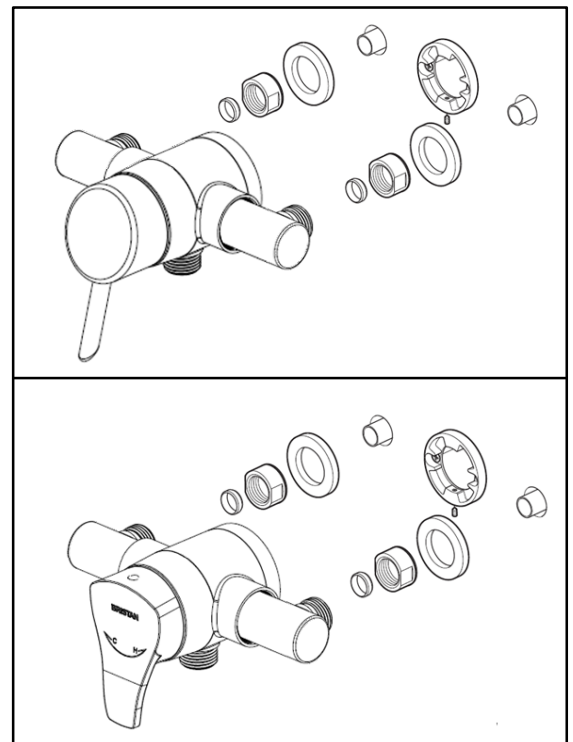

Installation – Riser Rail

1. Mark the position

Position the assembled riser rail onto the wall, bearing in mind the highest maximum position required for the handset. With the riser rail vertical, mark the position of the wall brackets onto the wall surface.

2. Attach wall bracket fixings

Remove the wall brackets from the rail and then remove the fixings from the wall brackets. Position the fixing bracket in the marked positions against the wall, ensure they are vertically in line with each other and mark the centres of the fixing holes onto the wall.

 **Warning:** Please check for any hidden pipes and cables before drilling holes in the wall.

Drill suitable holes and insert the wall plugs. Securely attach the fixing brackets to the wall using the screws.

Tips: A piece of insulation or masking tape positioned where holes are to be drilled and before marking out the exact position for the fixing holes will help stop the drill bit from wandering, particularly on a tiled surface. When working near a basin, bath or shower insert plug or cover waste to prevent losing small parts. Take care not to drop tools / equipment into basin, bath or shower during installation.

Note: If replacing an existing riser rail, check to see if the existing holes can be reused or covered by the new wall brackets. Try to avoid drilling close to the edge of tiles, drill in the middle of the tiles or in the tile joints.

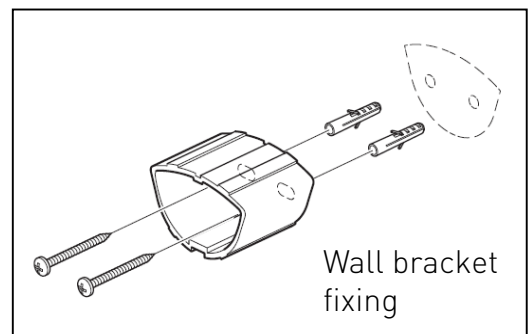
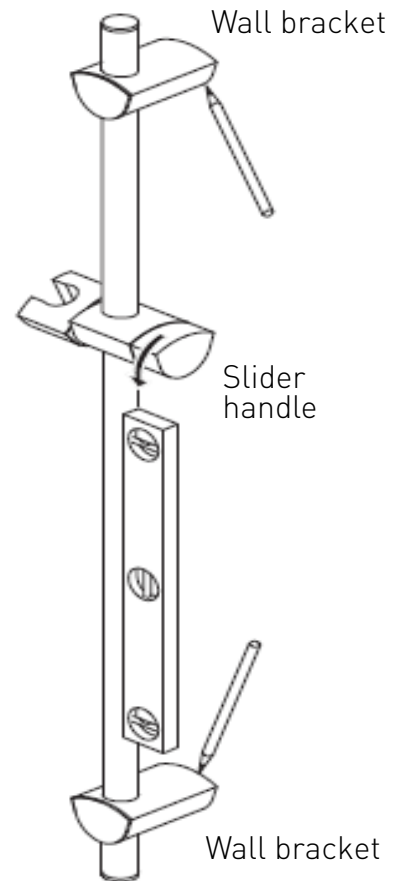

Installation – Riser Rail cont.

3. Insert rail clamps

Insert the rail clamps into both wall brackets.

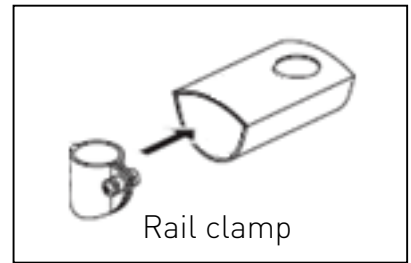

4. Insert riser rail

Push the riser rail up through the bottom wall bracket.

Push the slider down onto the riser, ensuring it is the correct way up - as shown opposite.

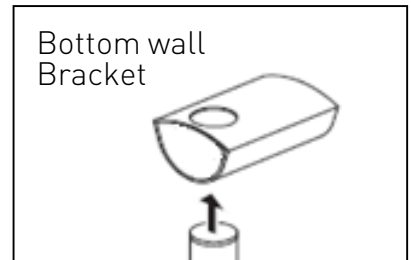

Then push the riser rail up through the top wall bracket.

5. Tighten rail clamps

Centre the riser rail within the wall brackets and tighten both clamps onto the rail.

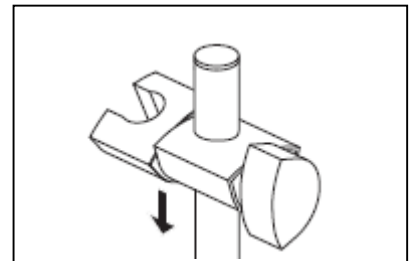

6. Fit the riser to the wall

Slide the riser brackets over the bracket fixings attached to the wall.

Tighten the grub screw on the underside of both top and bottom wall brackets using a 2.5mm hexagonal key.

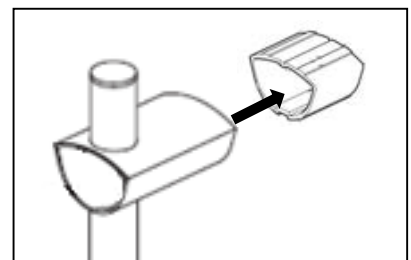
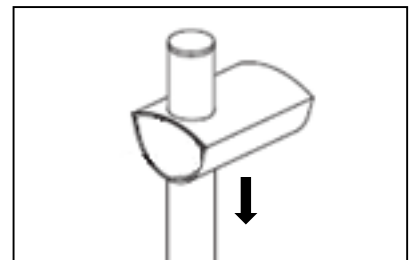

Installation – Riser Rail cont.

Attaching the Shower hose

7. Connect shower hose to shower valve / Wall outlet

Screw the shower hose (ribbed nut end) onto the shower valve / wall outlet ensuring that the rubber washer is fitted.

8. Connect shower hose to showerhead

Screw the shower hose (conical end) onto the showerhead ensuring that the rubber washer is fitted.

Place the showerhead into the slider.

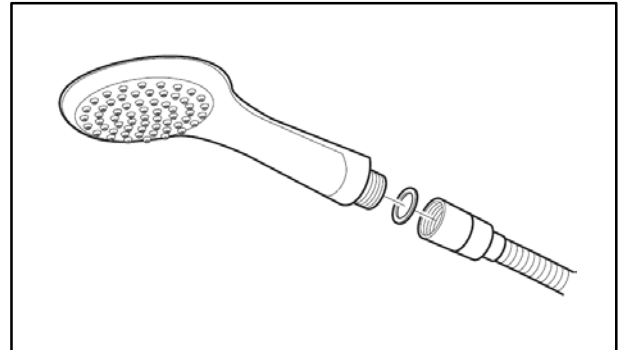
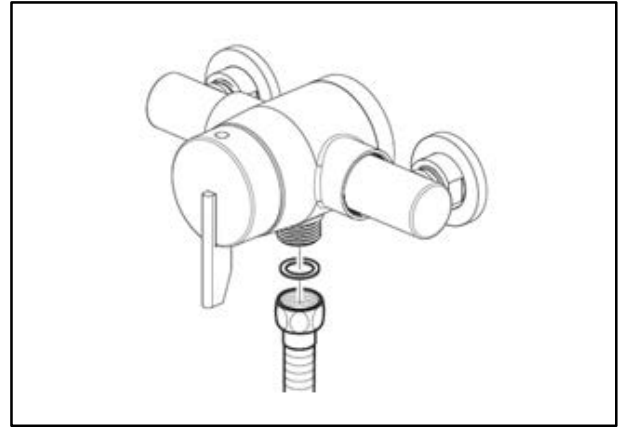

Operation

On/Off and Temperature Control

Turn the lever anti-clockwise to turn on and increase temperature.

Turn the lever clockwise to decrease temperature and turn off.

Riser rail

Turning the slider handle will allow the slider to be raised and lowered and the angle of the showerhead to be adjusted.

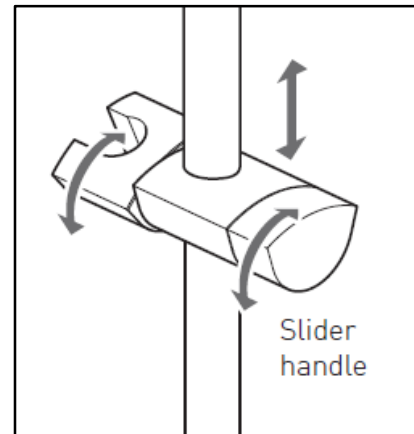
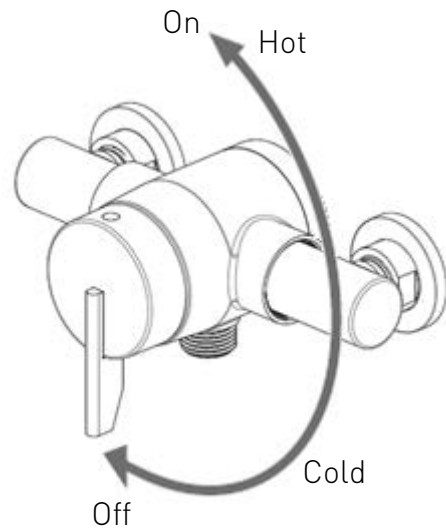

Commissioning

Commissioning notes for Thermostatic Mixing Valves

The first step in commissioning a thermostatic mixing valve is to check the following:

1. The designation of the thermostatic mixing valve matches the application.
2. The supply pressures are within the valves operating range.
3. The supply temperatures are within the valves operating range.
4. Isolating valves (and strainers preferred) are provided.

If all these conditions are met, proceed to set the temperature as stipulated in the Maintenance section.

The mixed water temperature at the terminal fitting must never exceed 46°C.

It is a requirement that all TMV2 approved valves shall be verified against the original set temperature results once a year. When commissioning / testing is due the following performance checks shall be carried out:

Measure the mixed water temperature at the outlet.

Carry out the cold water supply isolation test by isolating the cold water supply to the TMV, wait for five seconds, if water is still flowing check that the temperature is below 46°C.

If there is no significant change to the set outlet temperature (+/-2°C or less change from the original settings) and the fail-safe shut off is functioning then the valve is working correctly and no further service work is required.

Notes: If there is residual flow during the commissioning or the annual verification (cold water supply isolation test), then this is acceptable providing the temperature of the water seeping from the valve is no more than 2°C above the designated maximum mixed water outlet temperature setting of the valve.

Temperature readings should be taken at the normal flow rate after allowing for the system to stabilise.

The sensing part of the thermometer probe must be fully submerged in the water that is to be tested.

Any TMV that has been adjusted or serviced must be re-commissioned and re-tested in accordance with the instructions in the Maintenance section.

The installation of thermostatic mixing valves must comply with the requirements of the Water Supply (Water Fittings) Regulations 1999.

Maintenance

General Cleaning

Your fitting has a high quality finish and should be treated with care to preserve the visible surfaces. All surfaces will wear if not cleaned correctly. The only safe way to clean your mixer is to wipe with a soft damp cloth. Stains can be removed using washing up liquid. All bath cleaning powders and liquids will damage the surface of your fitting, even the non-scratch cleaners.

Note: Never use abrasive detergents or disinfectants or those containing alcohol, hydrochloric acid or phosphoric acid.

Cleaning the Showerhead

Your Bristan showerhead has rub-clean nozzles for easy cleaning. Simply rub your fingers across the rubber spray jets regularly and before you turn the shower on to remove any scale or debris.

The hardness of the water in your area will determine how often you should clean your showerhead. Build up of scale in particularly hard water areas combined with constant use means you may need to clean your showerhead once a week. To ensure continued performance of your shower the showerhead needs to be regularly descaled.

Cartridge Maintenance

We advise that the shower valve is regularly serviced in hard water areas to maintain the flow of water.

Isolate both hot and cold water supplies to the shower valve by either:

- Turning the water supply off at the mains stopcock or
 - Turning off the isolation valves to the shower valve
1. Remove the lever: remove the plastic cap, loosen the grub screw using a hexagonal key and carefully pull the lever off.
 2. Unscrew the cartridge anti-clockwise (using a suitable spanner) and remove from the valve body.
 3. Carefully remove the cartridge assembly and spring. Remove all visible 'O' rings and washers from the body.
 4. Place the cartridge in a bowl and carefully add hot water (just off the boil) and vinegar to de-scale the cartridge. Leave in the solution until the water has cooled and rinse with clean water.
 5. Replace all seals and grease with a silicon grease supplied by Bristan (part number: SP-495-0002) and carefully refit.
 6. Reset the maximum temperature and refit the handle and cover.

Maintenance cont.

Adjusting the Temperature

The shower valve has been factory set with equal (balanced) hot and cold water supply pressures with the hot water supply at 65°C.

If your operating conditions are different from those above, the outlet water temperature may differ from the factory setting.

If required the shower valve can be re-calibrated to suit your own temperature requirements.

Set the temperature control lever to maximum and check the temperature of the water with a thermometer. If the temperature is not correct, re-calibrate the shower valve.

1. Turn the lever anti-clockwise to the maximum temperature position.
2. Remove the lever: remove the plastic

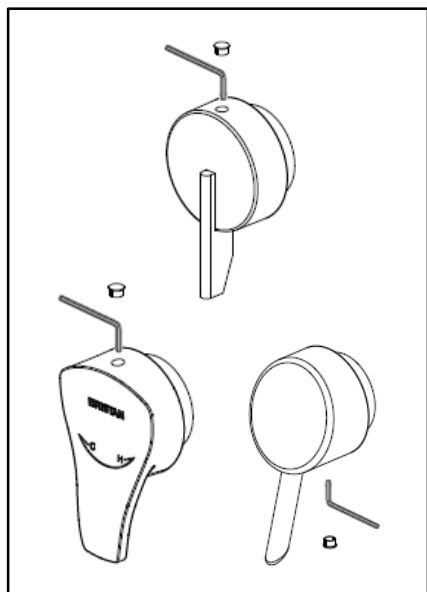

cap, loosen the grub screw using a hexagonal key and carefully pull the lever off.

3. Using the hexagonal key, turn the temperature adjusting screw to alter the temperature.

- Turn clockwise for a cooler temperature
- Turn anti-clockwise for a warmer temperature

Note: This will be the maximum temperature setting, it is recommended that the temperature is set no higher than 43°C.

4. Once the correct temperature is achieved, re-attach the lever and close the valve. Ensure the stop on the lever is in the correct position (vertically down), allowing the valve to turn on anti-clockwise.

5. Tighten the grub screw to lock the lever in place and push fit the plastic cap.

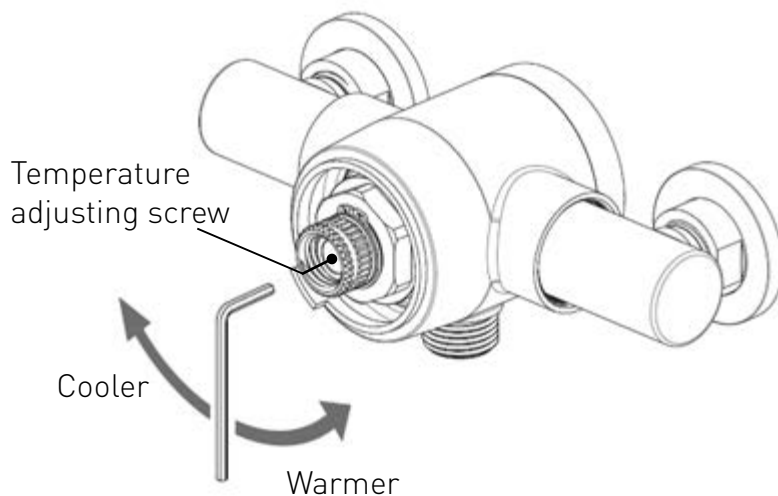

In-Service Testing

Purpose

The purpose of in service tests is to regularly monitor and record the performance of the thermostatic mixing valve.

Deterioration in performance can indicate the need for service work on the valve and / or water supplies.

Procedure

Using the same measuring equipment or equipment to the same specification as used in the commissioning section, adjust the temperature of the mixed water in accordance with the manufactures instructions and the requirement of the application, Carry out the following sequence.

- a) Record the temperature of the hot and cold water supplies.
- b) Record the temperature of the mixed water at the largest draw-off flow rate.
- c) Record the temperature of the mixed water at a smaller draw-off flow rate, which shall be measured.

If the mixed water temperature has changed significantly from the previous test results (e.g. >1K), record the change and before re-adjusting the mixed water temperature check:

- a) That any in-line or integral strainers are clean.
- b) Any in-line or integral check valves or other anti-back siphonage devices are in good working order.
- c) Any isolating valves are fully open.

With an acceptable mixed water temperature, complete the following procedure:

- a) Record the temperature of the hot and cold water supplies.
- b) Record the temperature of the mixed water at the largest draw-off flow rate.
- c) Record the temperature of the mixed water at a smaller draw-off flow rate, which shall be measured.
- d) Isolate the cold water supply to the mixing valve and monitor the mixed water temperature.
- e) Record the maximum temperature achieved as a result of (d) and the final stabilised temperature.
- f) Record the equipment, thermometer etc. used for the measurements.

If at step (e) the final mixed water temperature is greater than 41°C and / or the maximum temperature exceeds the corresponding value from the previous results by more than about 2K, the need for service work is indicated.

Note: In-service tests should be carried out with a frequency, which identifies a need for service work before an unsafe water temperature can result. In the absence of any other instruction or guidance, the procedure described in Annex F of D 08 may be used.

In-Service Testing cont.

Annex F of D 08 (informative)

Frequency of In-service tests

General

In the absence of any other instruction or guidance on the means of determining the appropriate frequency of in-service testing, the following procedure may be used:

- a) 6 to 8 weeks after commissioning carry out the tests in 'In-Service Tests'.
- b) 12 to 15 weeks after commissioning carry out the tests detailed in 'In-Service Tests'.

Depending on the results of the above tests, several possibilities exist:

- a) If no significant changes (e.g. $< 1\text{K}$) in mixed water temperatures are recorded between commissioning and 6 to 8 week testing, or between commissioning and 12 to 15 week testing the next in-service test can be deferred to 24 to 28 weeks after commissioning.
- b) If small changes (e.g. 1 to 2K) in mixed water temperatures are recorded in only one of these periods, necessitating adjustment of the mixed water temperature, then the next in-service test can be deferred to 24 to 28 weeks after commissioning.
- c) If small changes (e.g. 1 to 2K) in mixed water temperatures are recorded in both these periods, necessitating adjustment of the mixed water temperature, then the next in-service test should be carried out at 18 to 21 weeks after commissioning.
- d) If significant changes (e.g. $> 2\text{K}$) in mixed water temperatures are recorded in either of these periods, necessitating service work, then the next in-service test should be carried out at 18 to 21 weeks after commissioning.

Troubleshooting

Symptom	Cause	Remedy
No flow or low flow rate and / or varying temperatures.	Check showerhead, hose and filters for any blockage.	Clean as necessary, refer to Maintenance section (pages 23-24).
	Partially closed stop or service valve in water supply pipework to the shower valve.	Open stop or service valve.
	Instantaneous water heater cycles on and off as the flow rate or pressure is too low.	Increase water flow rate or pressure through system. Contact the boiler Manufacturer.
	Head of water is below the minimum distance required.	Raise the cistern or fit a shower booster pump.
	Inlet filter is partially blocked.	Clean or replace, flush through pipework before refitting.
	Hot or cold water is being drawn off elsewhere causing pressure changes or instantaneous boiler temperature changes.	Do not use other water outlets when using the shower.
	Make sure the maintained inlet pressures are nominally balanced and sufficient.	Refer to Installation Requirements section (pages 9-12).
	Airlock or potential blockage of the pipework.	Flush through pipework to ensure removal of debris and any airlocks.
	No hot or cold water reaching the shower valve.	Check hot and cold feeds (the valve will shut down if either the hot or cold supply fails).
Water leaking from showerhead.	This is normal for a short time after turning off.	Adjust the angle of showerhead in holder as necessary to vary draining time.
	Shower control valve failing to close fully, possibly due to water borne debris.	Remove shower control valve assembly and check. Refer to Maintenance section (pages 23-24). Before dismantling shower valve.
	Flow control valve seals damaged.	Check condition of flow control valve and replace as necessary.

Troubleshooting

Symptom	Cause	Remedy
Maximum water temperature too hot or cold.	Maximum water temperature set incorrectly.	Reset maximum water temperature. Refer to 'Maximum Temperature Setting' in Commissioning section (page 22) and Adjusting the Temperature in Maintenance section (pages 23-24).
Outlet water temperature too hot / cold.	Inlet filter partially blocked.	Check insert filters for any blockages and clean as necessary.
	Installation conditions outside operating parameters.	Refer to Installation Requirements section (pages 9-12). Service shower valve as recommended. Refer to maintenance section (page 23-24). Refer to Adjusting the Temperature section (page 24).
Water temperature too cold – maximum water temperature incorrectly set.	Hot water temperature is less than 10°C above the required blend temperature.	Adjust hot water temperature or wait for water to reheat if stored system is used.
	Instantaneous water heater not igniting because water flow rate is too low.	Increase water flow through the system. Check cartridge inlet filters and clean or replace. Refer to Maintenance section (pages 23-24). Contact the boiler manufacturer.
	Instantaneous water heater not igniting because the water pressure is too low.	Increase water pressure through system. Contact the boiler manufacturer.
Only hot or cold water from shower valve outlet.	Inlet water supplies are reversed (hot to cold supply).	Check the connections are the correct way round. Hot on the left and cold on the right when viewed from the front. Rework pipework as necessary.
	Inlet filter is partially blocked.	Clean or replace, flush through pipework before refitting.

Guarantee

At Bristan, we want to make things as easy as possible for our customers. That's why we offer solid guarantees on all our products, effective from the date of purchase, to give you peace of mind.

To start your free guarantee visit www.bristan.com/register.

For any other queries, please call our Customer Service on 0330 026 6273 where our expert team of advisors will be able to offer you any help and advice.

For full guarantee terms and conditions visit www.bristan.com/guarantees.

Notes

Notes

Part Number: FI SOQ2/CAP2/AE SHXAR C

Issue: D3

BRISTAN

Bristan Group Ltd.
Birch Coppice Business Park
Dordon
Tamworth
Staffordshire
B78 1SG
Web: www.bristan.com
Email: enquire@bristan.com

A Masco Company