

H64WMT2

COMMERCIAL Tap Range Thermostatic Wall Mount TMV3 HTM64 Mixer Tap



Specification

Product Type:	Commercial
Main Construction Material:	Brass
Mount Type:	Wall Mounted
Handle Type:	Lever
Connection Inlet:	15mm Compression with Eccentric Isolation
Connection Outlet:	Aerator and Open Outlet Options included
Number of Tap Holes:	2
Valve/Cartridge Type:	Thermostatic Sequential Cartridge
Plumbing System Requirements:	Suitable for all plumbing systems
Minimum Dynamic Pressure:	0.2 bar
Maximum Dynamic Pressure:	5.0 bar
Maximum Hot Water Temperature: °C	60
Maximum Static Pressure: (bar)	10
Flow Type:	Single
Isolation Included:	Yes
Pre-set Temperature °C:	41

Features:

- Complies with HTM04-01
- Safe Touch surface temperature
- Integral flush system assists against infection
- Smooth internal waterways
- 1-step isolation and filter removal

Product Certifications:



WRAS Certificate No: 2101906
WRAS Expiry Date: 31/01/2026



TMV3 Certificate No:
NSF2324/1020
TMV3 Expiry Date: 28/10/2025



For more products, visit our website:
<http://www.bristan.com>



Dimensions (measurements in mm)

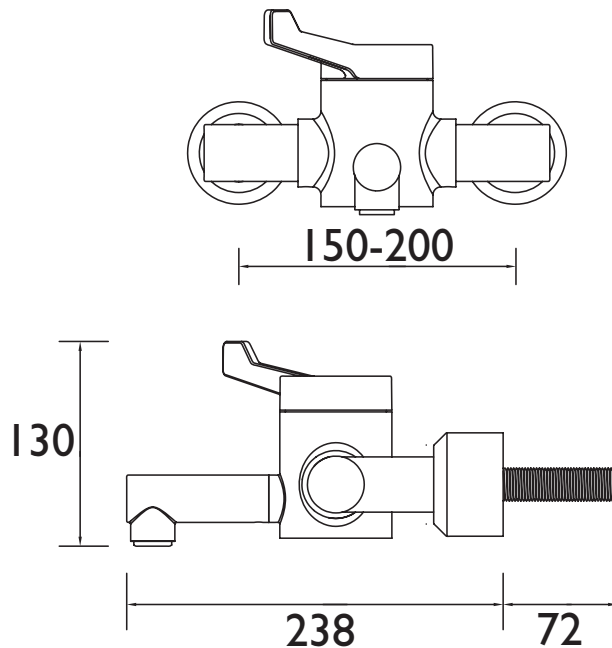

Flow Rates (l/min)

System Pressure (bar)	0.2	0.5	1	2	3	5
H64WMT2	1.5	2.3	3.3	4.7	5.7	7.4

TECHNICAL DATA SHEET



BRISTAN