

BRISTAN

Cadet Tap Range

Installation Instructions & User Guide

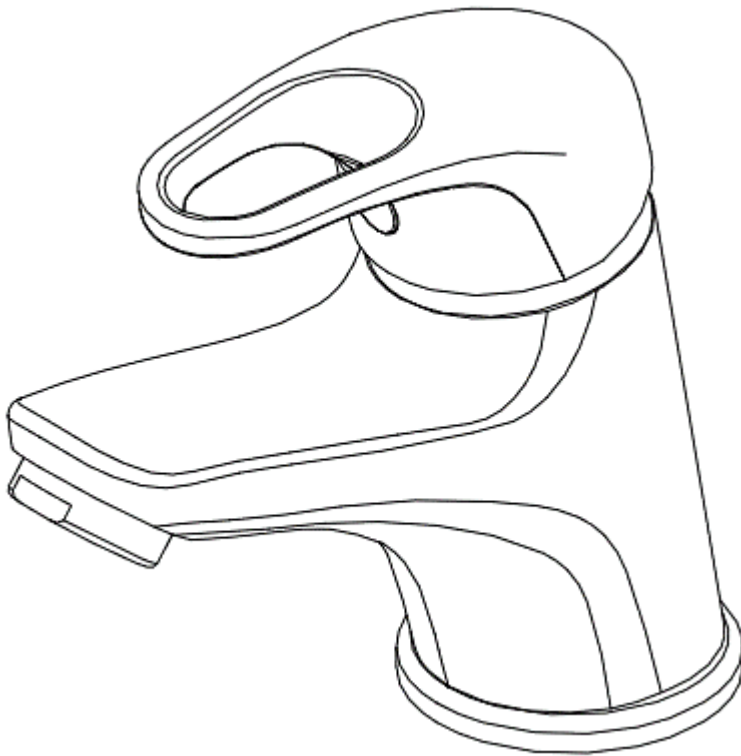

IMPORTANT: Please keep these instructions for future reference and request of replacement parts

Contents

Thank you for choosing Bristan, the UK's leading showers and taps expert.

We have designed this product with your enjoyment in mind. To ensure that it works to its full potential, it needs to be fitted correctly. These fitting instructions have been created to give you all of the information you need and, if you need any further help, please do not hesitate to give us a call on 0330 026 6273.

Important Safety Information	03
General Specifications	03
Installation	04-06
Maintenance	07-09
Troubleshooting	10
Guarantee	11

Important Safety Information

- Please read these instructions thoroughly and retain for future use.
- All products manufactured and supplied by Bristan are safe provided they are installed correctly, used correctly and receive regular maintenance in accordance with these instructions.
- **If you are in any doubt about your ability to install this product safely you must employ the services of an experienced qualified plumber.**
- Remove all packaging and check the components for damage before starting installation.



Before starting any installation please consider the following:

- Prior to drilling into walls, check that there are no hidden electrical wires, cables or water supply pipes. This can be checked with the aid of an electronic detector.
- If power tools are used do not forget to:
 - Wear eye protection
 - Unplug equipment after use
- This product **must** not be modified in any way as this will invalidate the guarantee.
- These fittings need to be installed in accordance with and meet the requirements of the Water Supply (Water Fittings) Regulations 1999 and Scottish Byelaws 2004.

General Specifications

Operating pressure range (bar)	Min	Max
CAD ½ C	0.2	5.0
CAD ¾ C	0.2	5.0
CAD BAS C	0.2	5.0
CAD BF C	0.2	5.0
CAD BSM C	0.2	5.0

Maximum static pressure - 10.0 bar

NOTE:- Nominally equal (balanced) inlet supply pressures are recommended for optimum performance of mixer taps.

Designed to comply with BS EN 200 for single taps / combination taps for water systems of type 1 and 2 general technical specifications; and to be used within systems designed to BS 6700. BS 6700 recommends the temperature of stored water should never exceed 65°C. A stored water temperature of 60°C is considered sufficient to meet all nominal requirements and will minimise the build up of lime scale in hard water areas.

Installation

Basin & Bath Taps

Identify all components are present prior to starting the installation.

1. Slide the plinth onto the threaded tail and fit the tap body to the basin / bath.
2. Slide the washer onto the threaded tail and secure the tap to the basin / bath by tightening the backnut. A suitable spanner may be required to fully tighten the backnut,
3. Connect the hot and cold water supplies to the threaded tails using either a $\frac{1}{2}$ " or $\frac{3}{4}$ " BSP connector (not supplied).
4. Turn on water supplies and turn both taps to the on position, letting the water flow for a few minutes.
5. Check all joints and connections for any leaks.

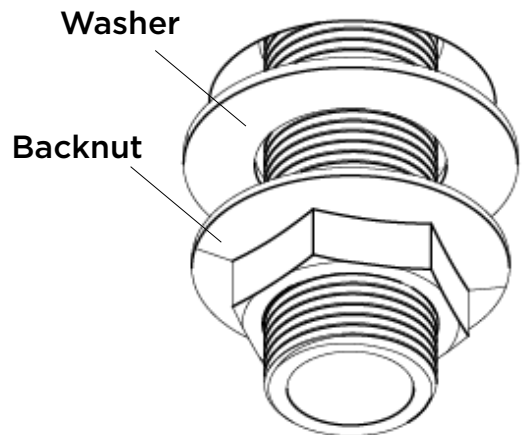
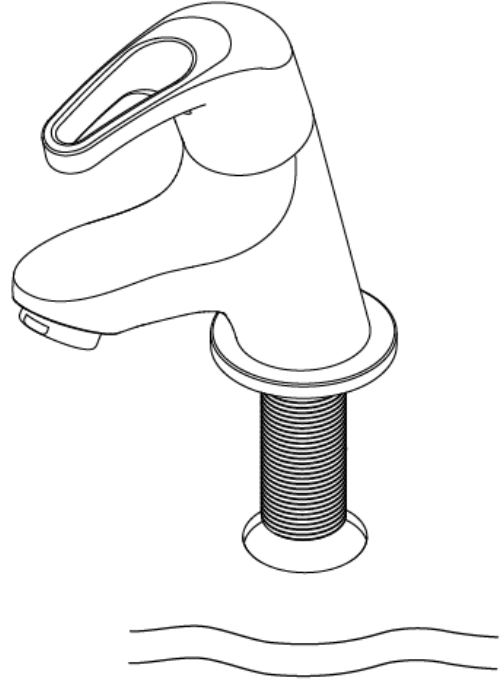

Installation cont.

Basin Mixer

Identify all components are present prior to starting the installation.

1. Screw the flexi tails into the bottom of the mixer body by **hand only (DO NOT OVERTIGHTEN)**.
2. Place the plinth over the hole in the basin and feed the flexi tails through the hole, ensuring the washer is fitted between the mixer body and the basin.
3. Screw the fixing rods into the bottom of the mixer body.
4. Slide 'C' shaped rubber washer and 'C' shaped metal washer onto the fixing rods up to the underside of the basin.
5. To secure the mixer in place tighten the fixing nuts onto the fixing rods until they are fully tightened against the 'C' shaped metal washer. The fixing nuts can be tightened with a suitable spanner.
6. Connect the flexi tails to the hot and cold water supplies.
7. Turn on water supplies, lift the mixer handle upwards and operate in both directions, letting the water flow for a few minutes.
8. Fit the clicker waste ensuring a rubber washer is fitted between the basin and the waste. Use a pure silicon sealant where necessary. Place the other rubber washer under the basin and secure by tightening the backnut, in order to fill the basin, the button in the middle of the waste needs to be pressed down. To release the water, press the button again.
9. Check all joints and connections for any leaks.

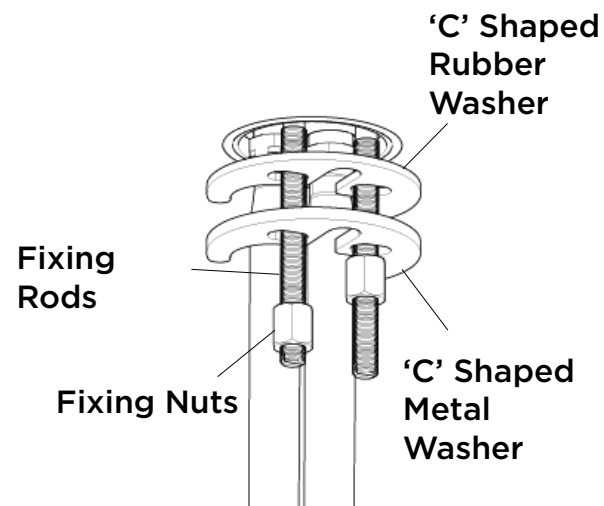
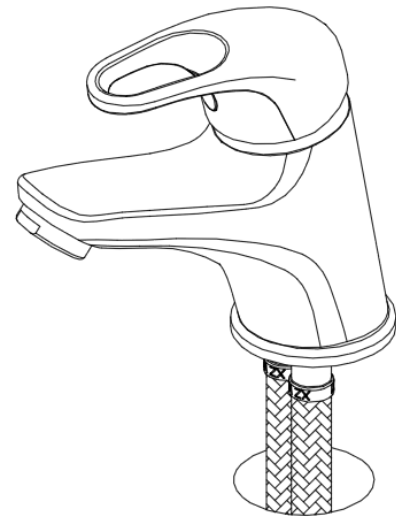
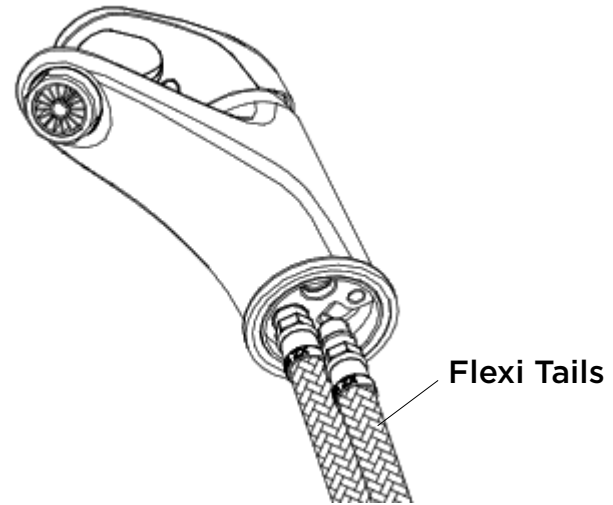

Installation cont.

Bath Filler and Bath Shower Mixer

Identify all components are present prior to starting the installation.

1. Fit the mixer body to the bath ensuring that the foam gasket is fitted between the mixer body and the bath.
2. Secure the mixer to the bath using the washer and metal backnut below the bath. Tighten the backnut onto the threaded tails. A suitable spanner may be required to fully tighten the backnut.
3. Connect the hot and cold water supplies to the threaded tails using a $\frac{3}{4}$ " BSP connector (not supplied).
4. **Bath Shower Mixer only** - fit the shower hose to the hose outlet using the small sealing washer, and the handset to the hose using the small washer.

 Prior the drilling into walls, check there no hidden electrical wires, cables or water supply pipes with the aid of an electronic detector.

If you use power tools do not forget to:

- Wear eye protection
- Unplug equipment after use

5. Fit the wall bracket (not shown) to the wall using the fixings supplied, ensuring the handset and hose reaches it.

To switch from bath to shower mode, pull the diverter knob up, to revert back to bath filling mode push the diverter knob back down.

6. Turn on water supplies and turn both handles into the on position, letting the water flow for a few minutes. Check all joins and connections for any leaks.

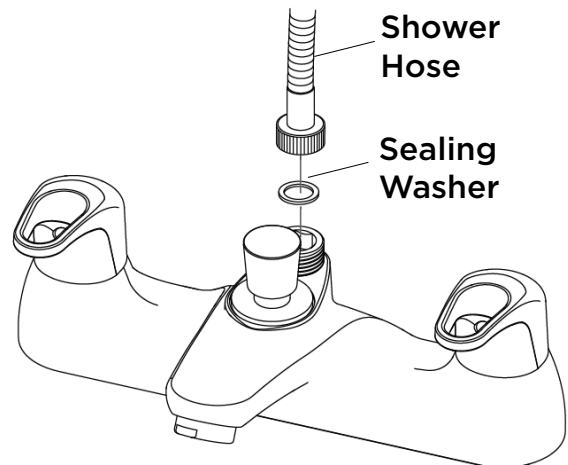
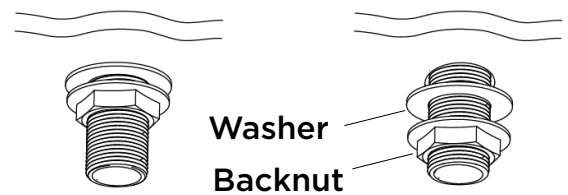
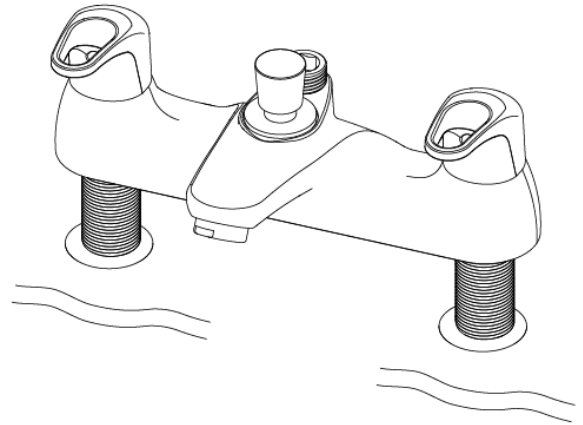

Maintenance

General Cleaning

Your fitting has a high quality finish and should be treated with care to preserve the visible surfaces. All finishes will wear if not cleaned correctly. The only safe way to clean your product is to wipe with a soft damp cloth. Stains can be removed using washing up liquid. All bathroom cleaning products (powders and liquids) will damage the surface of your fitting, even the non-scratch cleaners.

Note: Never use abrasive detergents or disinfectants or those containing alcohol, hydrochloric acid or phosphoric acid.

We advise that your fitting is regularly serviced in hard water areas to maintain optimum performance.

Cleaning the Showerhead:

CAD BSM C

Your Bristan showerhead has rub-clean nozzles for easy cleaning. Simply rub your fingers across the rubber spray jets regularly and before you turn the shower on to remove any scale or debris.

The hardness of the water in your area will determine how often you should clean your showerhead. Build up of scale in particularly hard water areas combined with constant use means you may need to clean your showerhead once a week. To ensure continued performance the showerhead needs to be regularly descaled.

Tip: If the showerhead is heavily scaled or has not been maintained for a long period of time a solution of hot water and white vinegar may be needed to clear the scale.

Mix a 50/50 solution and rub the nozzles thoroughly with the solution making sure the solution gets into all of the nozzles.

Wash off the solution with clean water.

Maintenance cont.

Cleaning the Valves (CAD ½ C, CAD ¾ C, CAD BF C, CAD BSM C):

If your fitting begins to leak the follow should be carried out:

Isolate both hot and cold water supplies to the tap by either:

- Turning the water supply off at the mains stopcock or
- Turning off the isolation valves to the tap

1. Prise out the handle cap, loosen the grub screw and pull the handle upwards.
2. Remove the spline adaptor.
3. Lift out the valve and clean thoroughly. Be sure to check and clean out the seating within the mixer body. If necessary replace the valve.
4. Please visit **www.bristan.com** and search for your product code in order to find spare parts for this product.
5. Place the valve back into the tap body and tighten the valve fully using a suitable spanner.
6. Replace the spline adaptor and push the handle onto the valve. Tighten the grub screw and push fit the cap.
7. Turn on water supply and check for leaks.
8. Contact our helpline if problem persists.

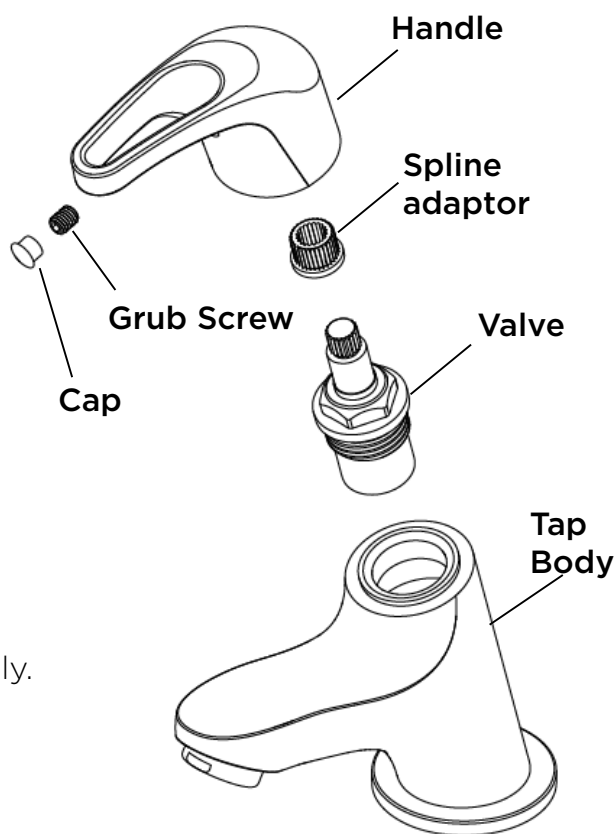

Maintenance cont.

Cleaning the Cartridge (CAD BAS C):

If your fitting begins to leak the following should be carried out;

Isolate both hot and cold water supplies to the tap by either:

- Turning the water supply off at the mains stopcock or
- Turning off the isolation valves to the tap.

1. Prise out the handle cap, loosen the grub screw and pull the handle upwards.
2. Unscrew the shroud and cartridge retaining nut and pull the cartridge out from the body.
3. Clean the cartridge thoroughly under cold water to remove any build up of limescale or debris. If necessary replace the cartridge
4. Please visit **www.bristan.com** and search for your product code in order to find spare parts for this product.
5. Replace the cartridge into the body and tighten the retaining nut to secure in place.
6. Screw the shroud onto the retaining nut and push the handle onto the cartridge. Tighten the grub screw and push fit the cap.
7. Turn on water supply and check for leaks.
8. Contact our helpline if problem persists.

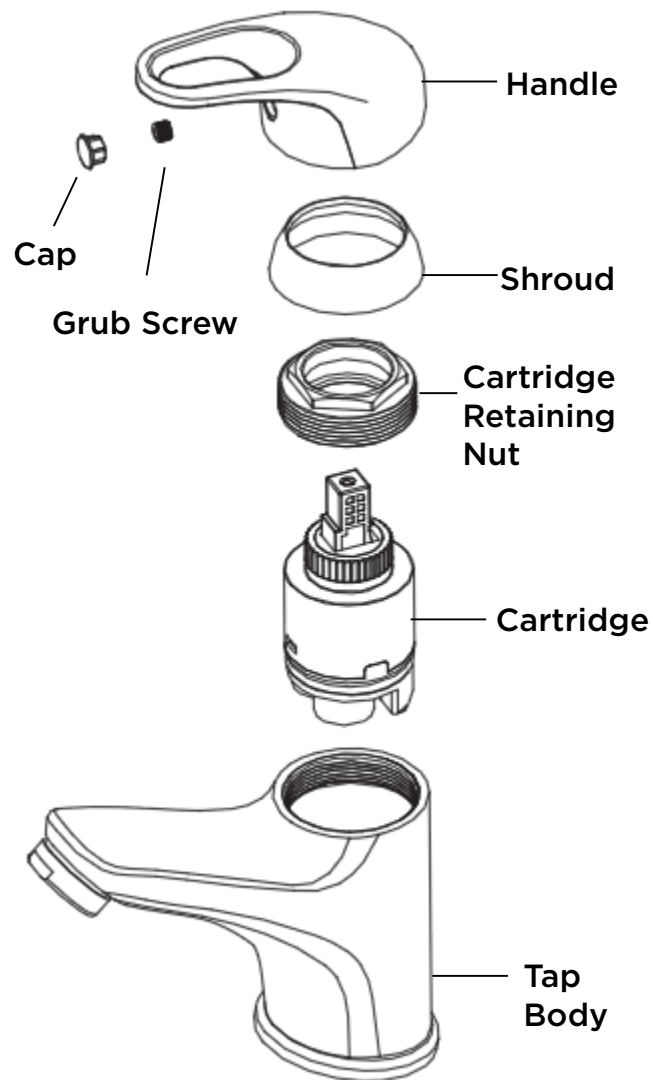

BRISTAN

Troubleshooting

Symptom	Cause	Remedy
No flow or poor flow rate.	Partially closed stop or service valve in water supply pipework to the tap.	Open stop or service valve.
	Head of water is below the minimum distance required.	Refer to the Specification section for minimum pressures required.
	Possible airlock / blockage in supply pipework	Remove water supplies from the fitting and flush the system to remove any airlocks / debris.
	Cartridge / Valve not opening fully.	Service fitting. Refer to maintenance section on pages 8-9.
Water dripping for a few seconds after the tap has been turned off.	This is caused by 'capillary action' and residual water in the spout being siphoned out.	This should only last for a couple of seconds, and is normal after use.
Constant dripping / leaking when the tap is not in use.	Cartridge / valve not fully shutting off.	Service fitting and replace cartridge/ valve. Refer to maintenance section on pages 8-9.
Fitting does not turn on.	Water supplies not turned on.	Check that the water supplies to the fitting are turned on.
	Closed stop or service valve.	Open stop or service valve.
Water does not come out of the showerhead when using the bath shower mixer.	Diverter mechanism not fully open.	Pull the diverter up fully.
	Insufficient water pressure / header height.	Refer to the specification section for minimum pressures required.

Bristan Guarantee

At Bristan, we want to make things as easy as possible for our customers. That's why we offer solid guarantees on all our products, effective from the date of purchase, to give you peace of mind.

To start your free guarantee, simply scan the QR code and Register your product.

Alternatively, visit www.bristan.com/register to register your product via a computer.

For full guarantee terms and conditions visit, www.bristan.com/guarantees



We Know & We Care

BRISTAN

This booklet covers product code:

CAD 1/2 C

CAD 3/4 C

CAD BAS C

CAD BF C

CAD BSM C

Helpline
0330 026 6273

Bristan Group Limited

Birch Coppice Business Park, Dordon, Tamworth, Staffordshire B78
1SG

A Masco Company

Website:

www.bristan.com

Telephone: 0330 026 6273

Email: enquire@bristan.com