

BRISTAN

Zing & Frenzy Cool Touch Bar Shower Valves

Installation Instructions & User Guide





Please keep these instructions for future reference and request of replacement parts

BRISTAN

Thank you for choosing Bristan, the UK's leading taps and showers expert. We have designed these products with your enjoyment in mind. To ensure that they work to their full potential, they need to be fitted correctly. These fitting instructions have been created to give you all of the Information you need and, if you need any further help, please do not hesitate to give us a call on 0844 701 6273.

Contents	Page
Important Safety Information	03
General Information	04
Specifications	05
Dimensions	06-07
Product Features	08
Installation Requirements	09-12
Installation	13-20
Operation	21
Setting	21
Commissioning	22
In-Service Testing	23-24
Maintenance	25
Map of Hard Water Regions in the UK	26
Troubleshooting	27-28
Guarantee	29

Important Safety Information

- Please read these instructions thoroughly and retain for future use.
- All products manufactured and supplied by Bristan are safe provided they are installed correctly, used correctly and receive regular maintenance in accordance with these instructions.
- If you are in any doubt about your ability to install this shower valve safely you must employ the services of an experienced qualified plumber.
- This shower valve needs to be installed in accordance with, and meet the requirements of the Water Supply (Water Fittings) Regulations 1999 and Scottish Byelaws 2004.
-  Warning: Do not operate the shower valve if you suspect it is frozen. Do not site the shower valve where it might be subjected to freezing conditions.
- Do not crush or kink the shower hose (where supplied) as this could damage the hose and cause leaks.
- Remove all packaging and check the contents for damage before starting installation.
-  Warning: Before starting any installation please consider the following: before drilling into walls, check that there are no hidden electrical wires, cables or water supply pipes. This can be checked with the aid of an electronic detector.
- If power tools are used do not forget to;
 - Wear eye protection
 - Unplug equipment after use
- Fitting Isolating valves to the inlet feeds is required for ease of maintenance.
-  Warning: Before installing the new shower valve it is essential that you thoroughly flush through the pipework in order to remove any remaining swarf, solder, etc. Failure to carry out this procedure could cause problems or damage to the workings of the shower valve.
- It is recommended that when installing the shower valve, full access is provided for servicing purposes.
- This shower valve must not be modified in any way as this will invalidate the guarantee.

General Information

This product complies with the BS EN 1111:1999 (HP) thermostatic mixing valve standards and satisfies the requirements of the Water Supply (Water Fittings) Regulations 1999 and current bylaws.

Designed to be used within systems designed to BS 6700.

BS 6700 recommends the temperature of stored water should never exceed 65°C. A stored water temperature of 60°C is considered sufficient to meet all normal requirements and will minimise the build up of lime scale in hard water areas (see Map of Hard Water Regions in the UK on page 24).

If the shower valve is installed at low pressure (tank fed), then the minimum distance from the highest installed position of the showerhead to the underside of the cold tank should be at least 2 metres to ensure adequate performance.

These shower valves should be installed in compliance with the Water Regulations. For further details contact your Local Water Authority.

Specifications

Inlet Connections: G ½" male thread with 135-165mm centres (Zing)
15mm compression with 150mm between centres (Frenzy)

Operating Pressure Range: Minimum. 0.2bar, Maximum 5.0bar.
Maximum Static Pressure: 10.0bar.

Note: Nominally equal (balanced) inlet supply pressures are required for optimum performance. If pressures are unequal, then a pressure reducing valve should be used.

Maximum recommended imbalance between hot and cold supply should not exceed a ratio of 5:1

Maximum Outlet Temperature: Factory pre-set to 38°C with push button override to 46°C (can be re-set to suit site conditions or personal preference).

Supply Requirements:

Minimum cold water supply temperature: 5°C

Maximum cold water supply temperature: 25°C

Maximum hot water supply temperature: 80°C

(a maximum hot water supply of 55-65°C is recommended for ablutionary purposes).

Note: The inlet hot water temperature must be at least 10°C above the required blend temperature (e.g. outlet temperature 43°C: Minimum hot supply 53°C).

Note: Valves operating outside these conditions cannot be guaranteed by the Scheme to operate as Type 2 valves.

Dimensions - Zing Shower Valve with Adjustable Riser

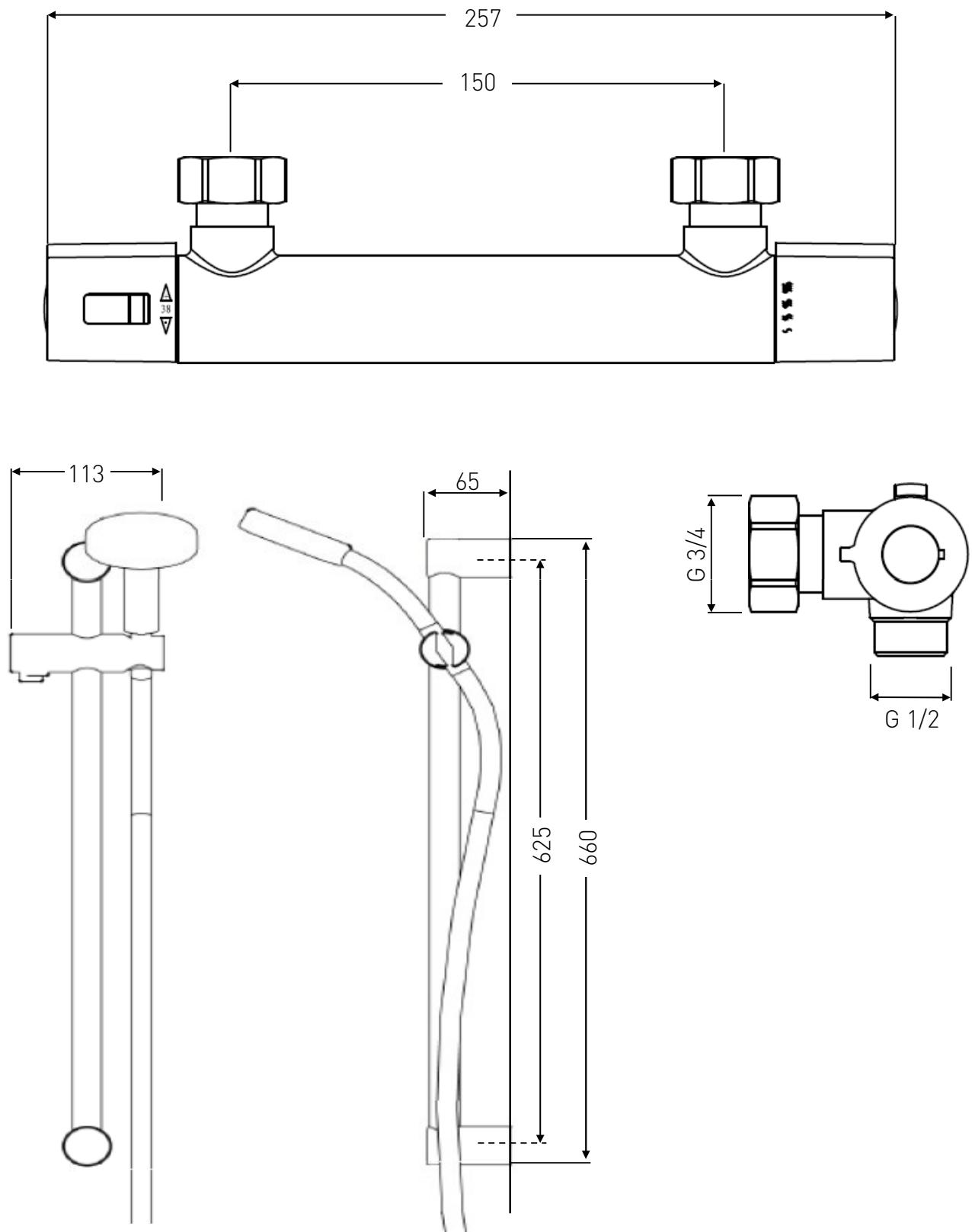

All dimensions are in mm's and are approximate.

Dimensions - Frenzy Shower Valve Only & Shower Valve with Adjustable Riser

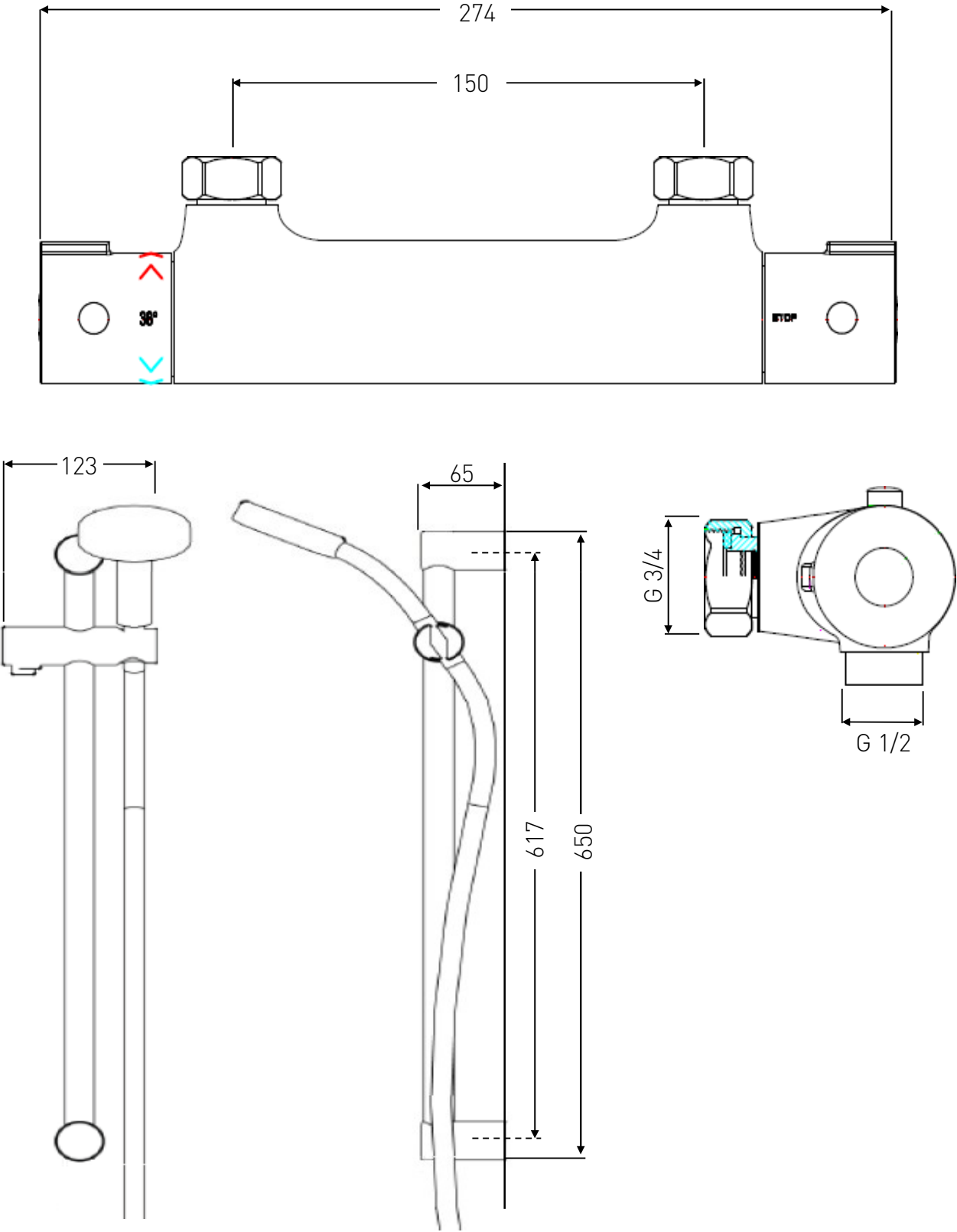

All dimensions are in mm's and are approximate.

Product Features

1. Water Flow Control

Controls the amount or flow of water from the showerhead.

Note: The Frenzy shower valve has an Eco feature. Press the button in on handle (1) and continue to turn the handle for an increased flow rate.

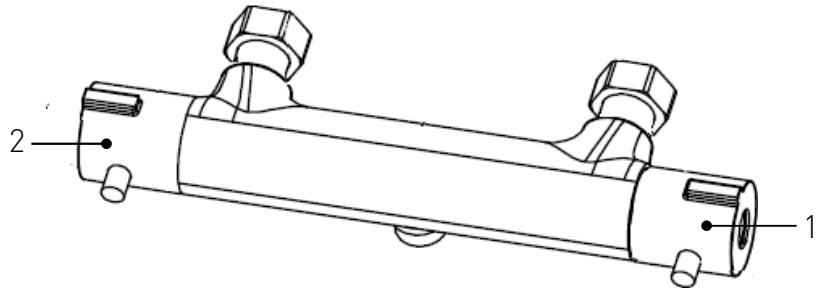

2. Temperature Control

Adjustable temperature control.

The temperature control incorporates a safety stop facility limiting the water temperature to 38°C.

To obtain a higher water temperature, press / slide the button on handle (2) and continue to turn the control to the desired temperature.

Cool Touch Feature

These shower valves incorporate a cool touch feature. When the shower valve is in use the body of the shower will not get hot and will remain cool.

Installation Requirements

This shower valve must be installed in compliance with current water regulations. If you have any doubts about the water regulation requirements contact your local water services provider or use the services of a professional plumber.

This shower valve is suitable for use with the following water supply systems.

- Gravity Fed Hot and Cold (pressure Balanced)
- Gravity Fed Hot and Mains Cold (differential pressure – see Specification section on page 5.
- Instantaneous Water Heater (combination boiler)
- Unvented System
- Pumped System

Gravity Fed Hot and Cold

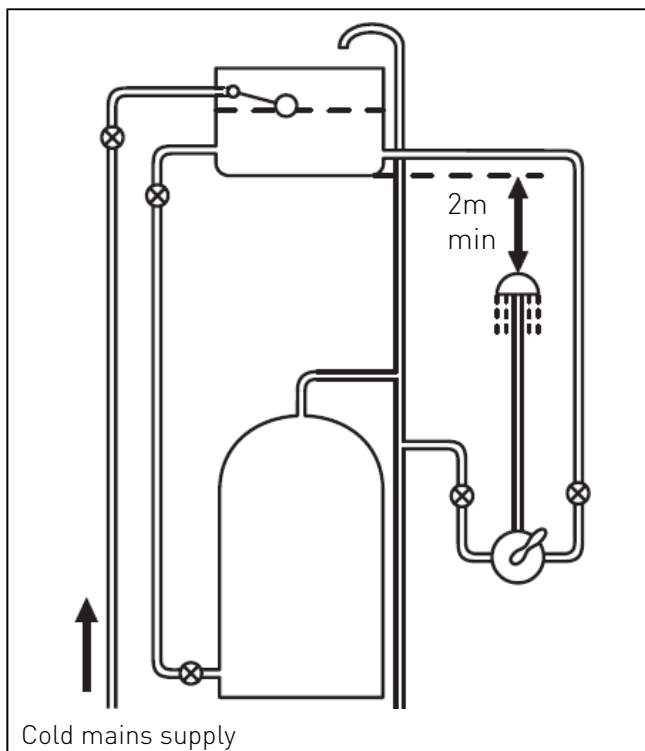

! Important: If you install this shower valve with a gravity fed system, there must be a minimum head (vertical distance) from the underside of the cold water storage tank to the showerhead position of at least 2 metres.

Note: Pumped system (with Essex flange) If you install this shower valve to a pumped gravity fed system where the minimum head (vertical distance) from the underside of the cold water storage tank to the top of the hot water cylinder is less than 1 metre we recommend an Essex flange is used as shown on page 10.

Flushing Pipework

! Important: Before connecting the shower valve (see Installation on pages 13-20), supply pipework must be flushed to clear debris before connecting the shower valve. Debris will reduce the performance and life of the shower.

Gravity Fed Hot and Mains Cold

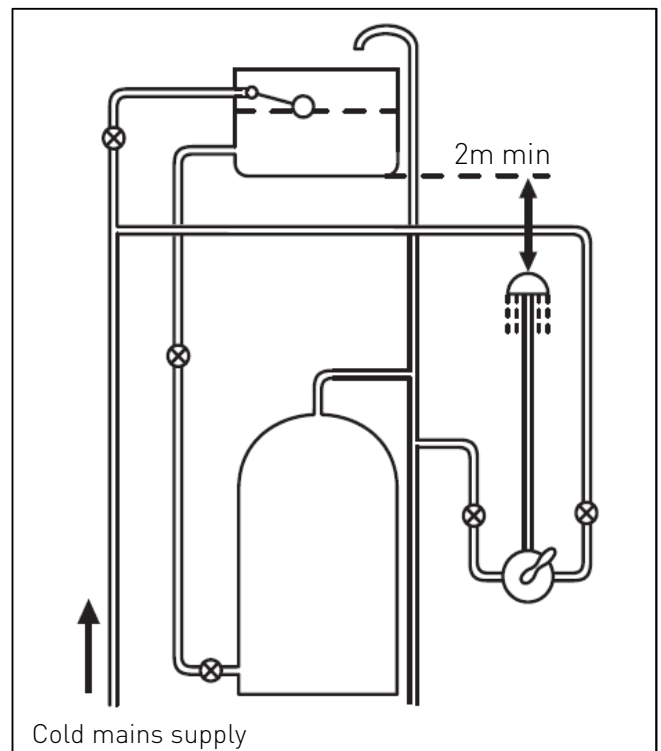

Installation Requirements

Instantaneous Water Heater

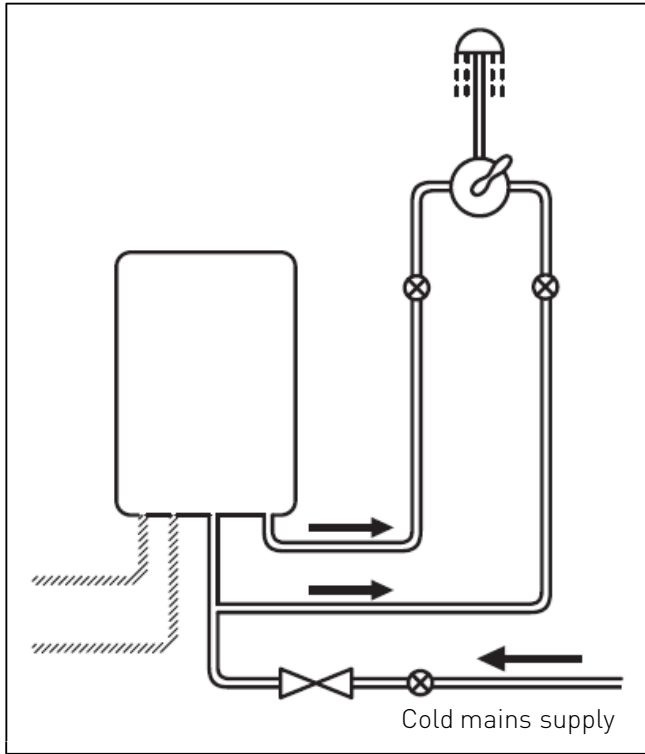

Unvented System

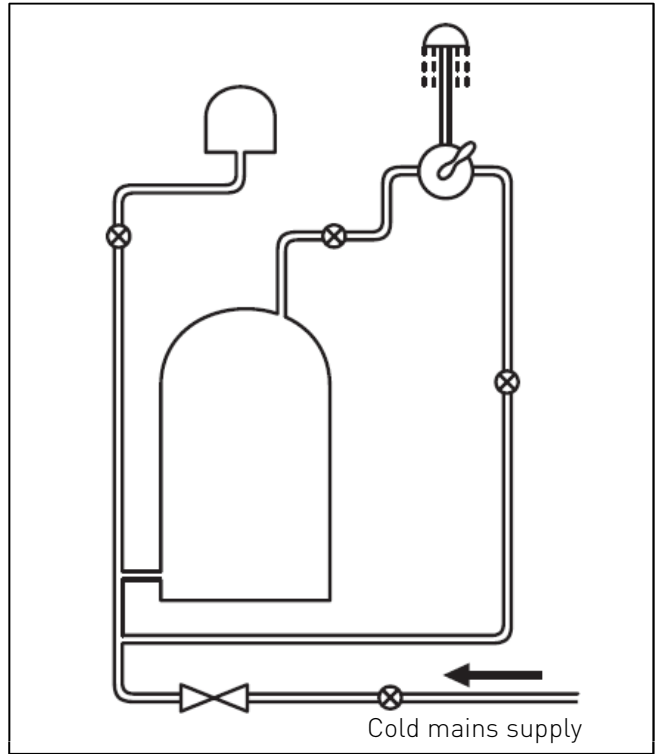

Pumped System

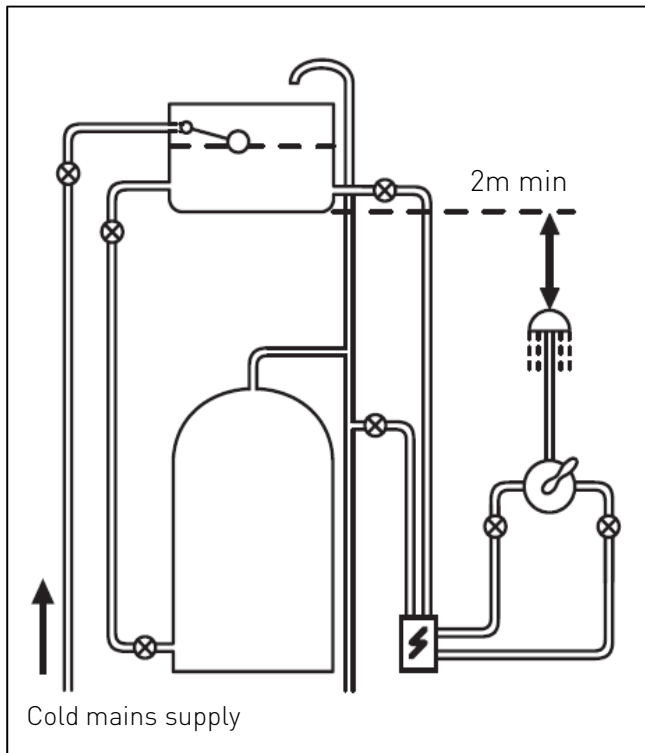

Pumped System (with Essex flange)

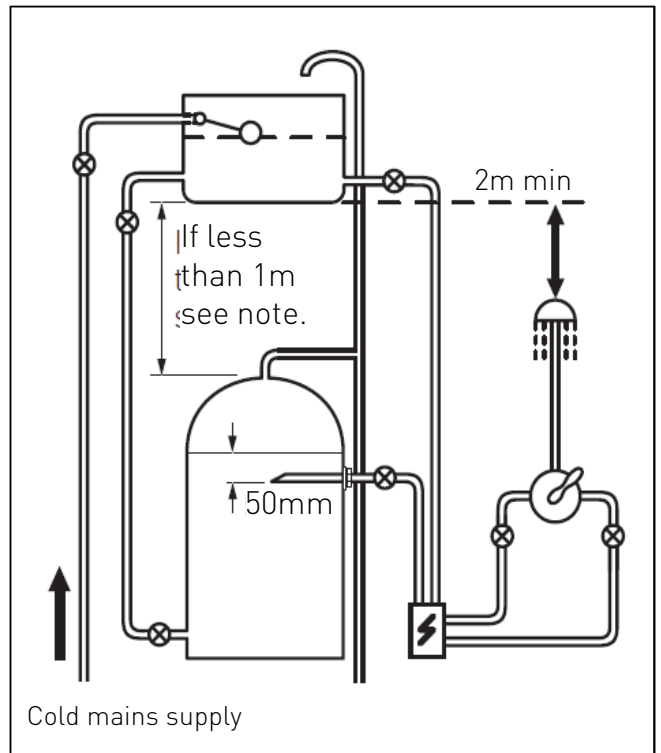

Key:

	Isolating Valve		Reducing Valve		Shower Valve		Pump		Essex Flange
--	-----------------	--	----------------	--	--------------	--	------	--	--------------

Installation Requirements

These fittings need to be installed in accordance with the following Installation Requirements and Notes (IRN) to ensure they meet the requirements of the Water Supply (Water Fittings) Regulations 1999 and the Scottish Byelaws 2004.

IRN R001: See text of entry for Installation Requirements or Notes.

IRN R040 - Schedule 2-15 (1): The fitting shall be installed so that its outlet discharges above the spill-over level of any fixed appliance as indicated below:-

For backflow protection in domestic or installations up to, and including, Fluid Category 3.

If the fitting cannot be installed as indicated in the table opposite it shall be installed as either a or b below:

a: with an approved double check valve assembly or some other no less effective backflow prevention device immediately upstream of the inlet.

b: so that it draws water by gravity only from a cistern, or cylinder having a permanently open vent pipe, and the distributing pipe supplies no other fitting (other than draining tap) at a lower level.

For backflow protection in premises or installations up to, and including Fluid Category 5.

The vertical distance of the outlet above the spill-over level shall be not less than 20mm or twice the diameter of the inlet pipe to the fitting, which ever is the greater. If the fitting cannot be installed as indicated it shall be installed with a backflow prevention arrangement suitable for the Fluid Category.

Size of tap or combination fitting.	Vertical distance of outlet above spill-over level.
1. Not exceeding 1/2 in	20mm
2. Exceeding 1/2 in but not exceeding 3/4 in	25mm
3. Exceeding 3/4 in	70mm

Installation Requirements

This valve has been approved for use in the following designations:		
Code	Operating Pressure	Application
HP-S	High Pressure	Shower
HP-W	High Pressure	Wash Basin

Valves operating outside these conditions cannot be guaranteed by the Scheme to operate as Type 2 valves.

If a water supply is fed by gravity then the supply pressure should be verified to ensure the conditions of use are appropriate for the valve.

Recommended Outlet temperatures

We recommend the following set maximum mixed water outlet temperatures for use in all premises:

41°C for showers;

The mixed water temperatures must never exceed 46°C.

The maximum mixed water temperature can be 2°C above the recommended maximum set outlet temperatures.

Conditions of Use for Thermostatic Mixer Valves	
	High Pressure
Maximum Static Pressure (Bar)	10
Flow Pressure, Hot & Cold (Bar)	0.5 to 5
Hot Supply Temperature (°C)	55 to 65
Cold Supply Temperature (°C)	Equal to or Less than 25

Note: 46°C is the maximum mixed water temperature from the bath tap. The maximum temperature takes account of the allowable temperature tolerances inherent in thermostatic mixing valves and temperature losses in metal baths.



Warning: It is not a safe bathing temperature for adults or children.

The British Burns Association recommends 37 to 37.5°C as a comfortable bathing temperature for children. In premises covered by the Care Standards Act 2000, the maximum mixed water outlet temperature is 43°C.

The thermostatic mixing valve (TMV) will be installed in such a position that maintenance of the TMV and its valves and the commissioning and testing of the TMV can be undertaken.

The fitting of isolation valves is required as close as is practical to the water supply inlets of the thermostatic mixing valve.

Installation – Zing Shower Valve with Adjustable Riser

This Thermostatic Mixer Valve should be installed in compliance with Water Regulations (refer to General Information section). For further details contact your Local Water Authority.

This TMV is suitable for use with the following systems:

- Gravity Fed Hot & Cold (Nominally Equal Pressure)
- Gravity Fed Hot & Mains Cold (Differential Pressure, Max ratio 5:1)
- Unvented Systems
- Instantaneous Water Heater (Combination Boiler)
- Pumped System

Note: On Gravity systems the minimum distance from the underside of the cold water storage tank to the shower handset must be at least 2 metres.

 Warning: Before installing the thermostatic mixer valve it is essential that you thoroughly flush through the pipework in order to remove any remaining swarf, solder, etc. Failure to carry out this procedure could cause problems or damage to the workings of the mixer valve.

Installing the Connectors

1. Identify all components are present prior to starting installation (see overleaf).
2. Attach the connectors (1) to the shower valve and mark out the position for the pipework.

Note: The Pipe centres required for this Thermostatic Mixing Valve are variable between 135-165mm.

 Before drilling into walls, check that there are no hidden electrical wires, cables or water supply pipes. This can be checked with the aid of an electronic detector.

- If power tools are used do not forget to;
 - Wear eye protection
 - Unplug equipment after use

3. Drill suitable holes in the wall surface at the marked positions to accommodate the supply pipework.

4. Terminate the pipework in the wall ensuring that the pipework is sunk in the wall.

IMPORTANT: The water supply pipes to the thermostatic Mixer Valve must be with the Hot on the left and the Cold on the right when viewed from the front.

5. Secure the connectors (1) to the pipework using ½" BSP female connectors (not supplied) ensuring the connectors protrude out of the wall Surface as shown in Fig.1.

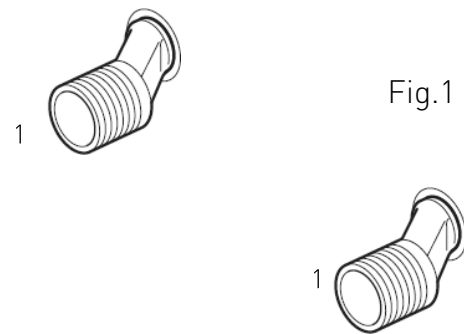

6. Screw the shrouds (2) onto the connectors (1) see (Fig 3).

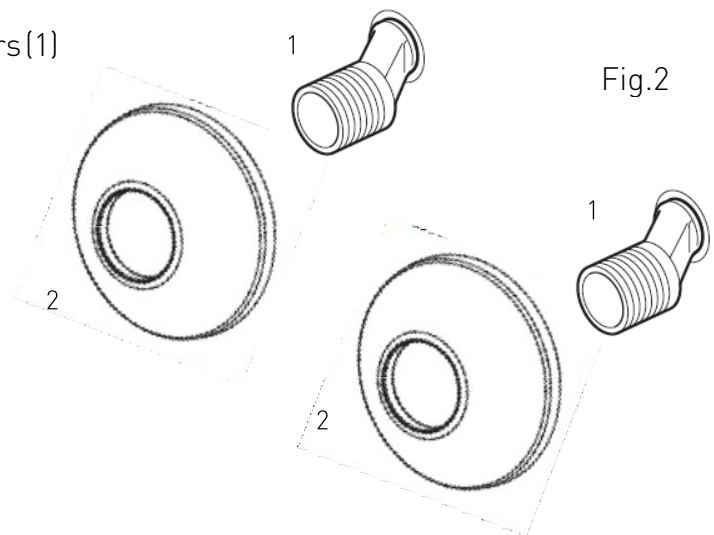

Installing the Thermostatic Mixer Valve

1. Place the filter washers (3) into the connectors (1)
2. Position the shower valve (4) against the connectors (1) and carefully tighten the shower valve fixing nuts onto the connectors (1). Do not overtighten.

Note: Take care not to damage the finish of the shower valve fixing nuts. Protect the chromium plated surfaces with a cloth.

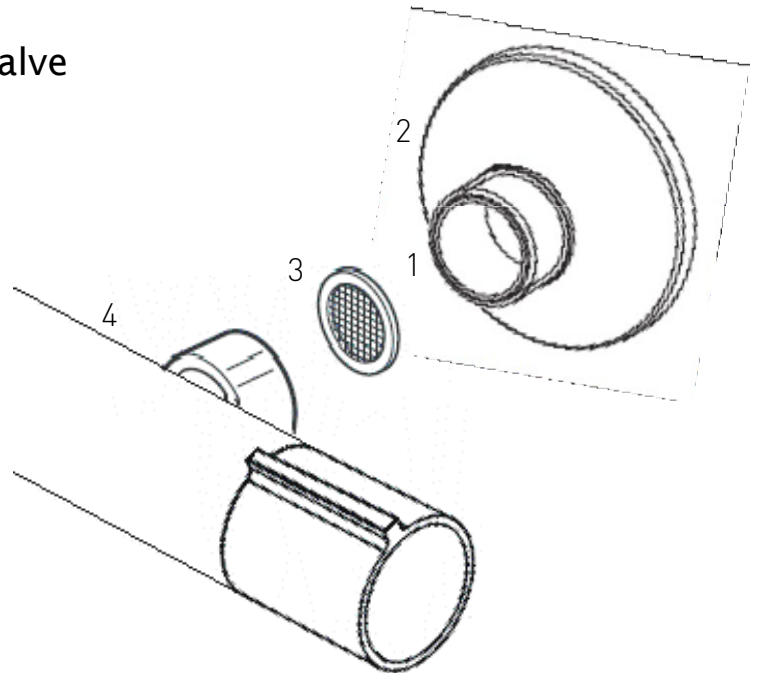

Installing the Adjustable Riser (See diagram overleaf)

1. Offer the adjustable riser (9) with the riser brackets (10) attached on to the wall surface and mark the position of the brackets (10) ensuring that the handset and hose will reach the handset holder when it is in its highest position.
2. Using the positions marked on the wall surface drill suitable holes for the fixings (11).
3. Fix the bottom riser bracket (10) to the wall using the fixings (11) supplied, the top riser bracket (10) is fixed at a later stage.
4. Slide the handset holder (13) and the hose retainer (14) onto the adjustable riser (9). The top of the adjustable riser (9) has a hole through the middle.
5. Fit the bottom of the adjustable riser (9) into the bottom bracket (10).
6. Push the top bracket (10) onto the top of the riser (9) ensuring the hole in the top of the riser is in the centre of the bracket (10) when viewed from the front.
7. Fix the top bracket (10) to the wall using the fixings (11) supplied.
8. Push the bracket end caps (12) onto the riser brackets (10).
9. Attach the shower hose (15) onto the outlet of the shower valve (8) using the small washer provided and attach the conical end of the shower hose (15) onto the handset (16) using the small washer provided. The conical end of the shower hose (15) fits into the handset holder (13) and not the handset (16).

BRISTAN

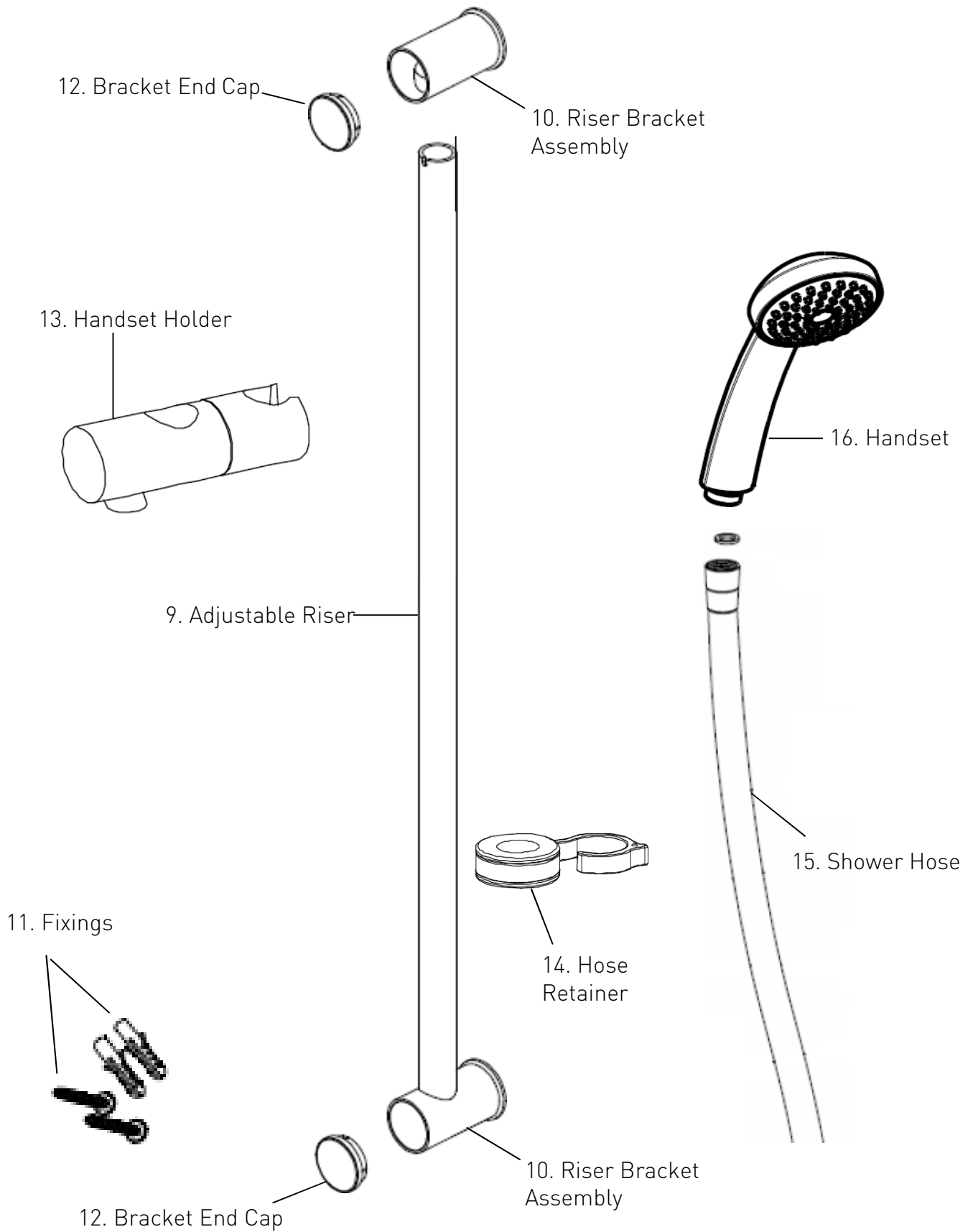

Installation – Frenzy Shower Valve only & Frenzy Shower Valve with Adjustable Riser

This Thermostatic Mixer Valve should be installed in compliance with Water Regulations (refer to General Information section). For further details contact your Local Water Authority.

This TMV is suitable for use with the following systems:

- Gravity Fed Hot & Cold (Nominally Equal Pressure)
- Gravity Fed Hot & Mains Cold (Differential Pressure, Max ratio 5:1)
- Unvented Systems
- Instantaneous Water Heater (Combination Boiler)
- Pumped System

Note: On Gravity systems the minimum distance from the underside of the cold water storage tank to the shower handset must be at least 2 metres.



Warning: Before installing the thermostatic mixer valve it is essential that you thoroughly flush through the pipework in order to remove any remaining swarf, solder, etc. Failure to carry out this procedure could cause problems or damage to the workings of the mixer valve.

Installing the Fast Fit Kit

1. Identify all components are present prior to starting installation.
2. Using the template supplied with the fast fit kit mark out the position for the pipework and the fixings supplied.

Note: The Pipe centres required for this Thermostatic Mixing Valve are 150mm.



Before drilling into walls, check that there are no hidden electrical wires, cables or water supply pipes. This can be checked with the aid of an electronic detector.

- If power tools are used do not forget to;
 - Wear eye protection
 - Unplug equipment after use

3. Drill suitable holes in the wall surface at the marked positions to accommodate the supply pipework and fixings.

4. Terminate the pipework in the wall ensuring that there is at least 30mm of 15mm diameter pipework protruding from the finished wall surface (See Fig.1).

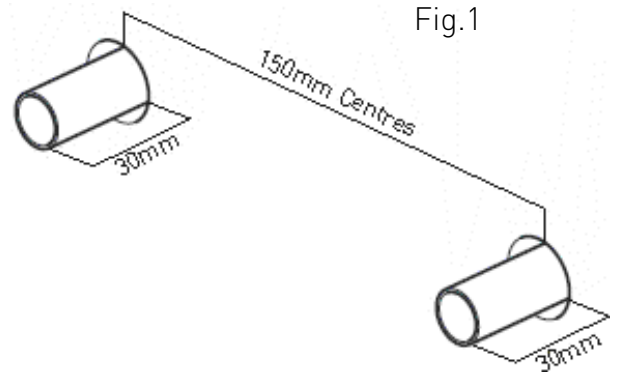

IMPORTANT: The water supply pipes to the thermostatic Mixer Valve must be with the Hot on the left and the Cold on the right when viewed from the front.

5. Place the wall plates (1) over the supply pipes. Using the wall plugs (2) and screws (3) provided fix the wall plates to the wall (See Fig.2).

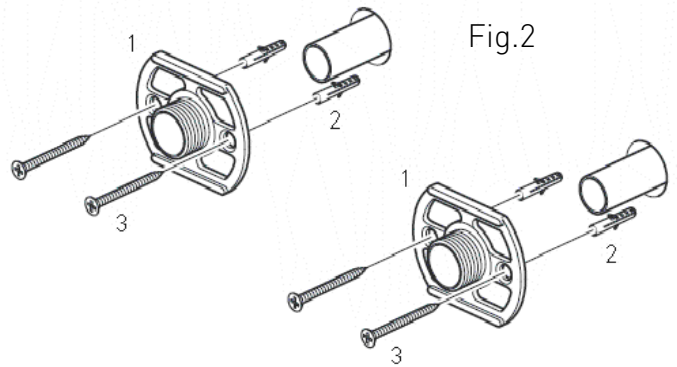

6. Place the olives (4) onto the protruding pipework (See Fig.3).

IMPORTANT: The pipework must not protrude past the olive (4) by more than 5mm.

7. Holding the flat edges of the wall plate (1) with a 47mm spanner screw the fixing bridge (5) onto the wall plate (1) using a 22mm spanner. Repeat this step on both sides (See Fig.3).

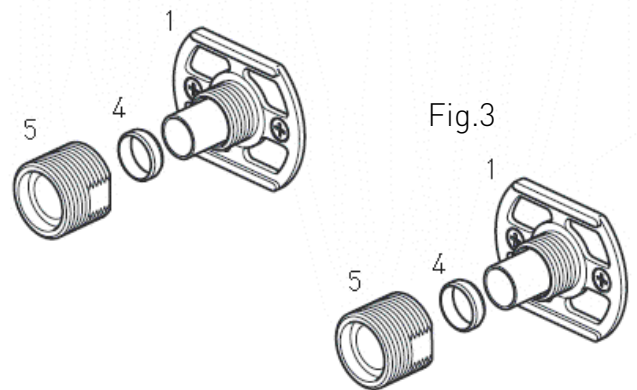

8. Screw the covers (6) over the wall plates / fixing bridges (5), so they are flush against the finished wall surface (See Fig.4).

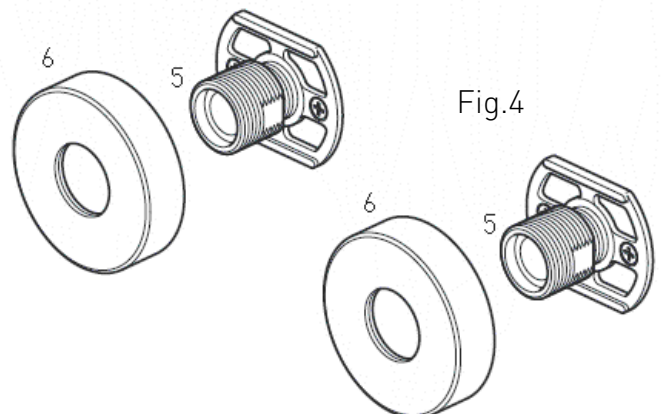

Installing the Thermostatic Mixer Valve

1. Place the filter washers (7) into the shower valve fixing nuts.
2. Position the shower valve (8) against the fixing bridges (5) and carefully tighten the shower valve fixing nuts onto the fixing bridges (5). Do not overtighten.

Note: Take care not to damage the finish of the shower valve fixing nuts. Protect the chromium plated surfaces with a cloth.

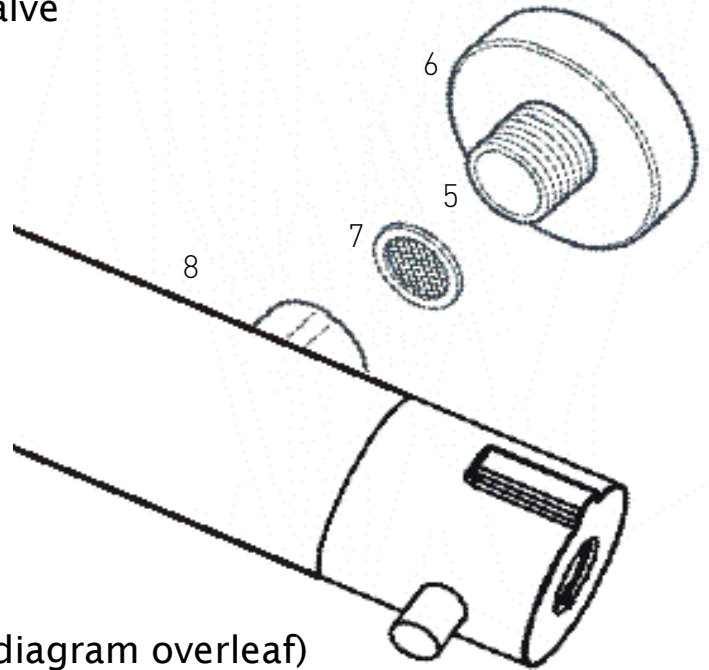

Installing the Adjustable Riser (See diagram overleaf)

1. Offer the adjustable riser (9) with the riser brackets (10) attached on to the wall surface and mark the position of the brackets (10) ensuring that the handset and hose will reach the handset holder when it is in its highest position.
2. Using the positions marked on the wall surface drill suitable holes for the fixings (11).
3. Fix the bottom riser bracket (10) to the wall using the fixings (11) supplied, the top riser bracket (10) is fixed at a later stage.
4. Slide the handset holder (13) and the hose retainer (14) onto the adjustable riser (9). The top of the adjustable riser (9) has cut outs to the top and bottom which need to face the front.
5. Fit the bottom of the adjustable riser (9) into the bottom bracket (10).
6. Push the top bracket (10) onto the top of the riser (9) ensuring the cut out in the top of the riser is in the centre of the bracket (10) when viewed from the front.
7. Fix the top bracket (10) to the wall using the fixings (11) supplied.
8. Push the bracket end caps (12) onto the riser brackets (10).
9. Attach the shower hose (15) onto the outlet of the shower valve (8) using the small washer provided and attach the conical end of the shower hose (15) onto the handset (16) using the small washer provided. The conical end of the shower hose (15) fits into the handset holder (13) and not the handset (16).

BRISTAN

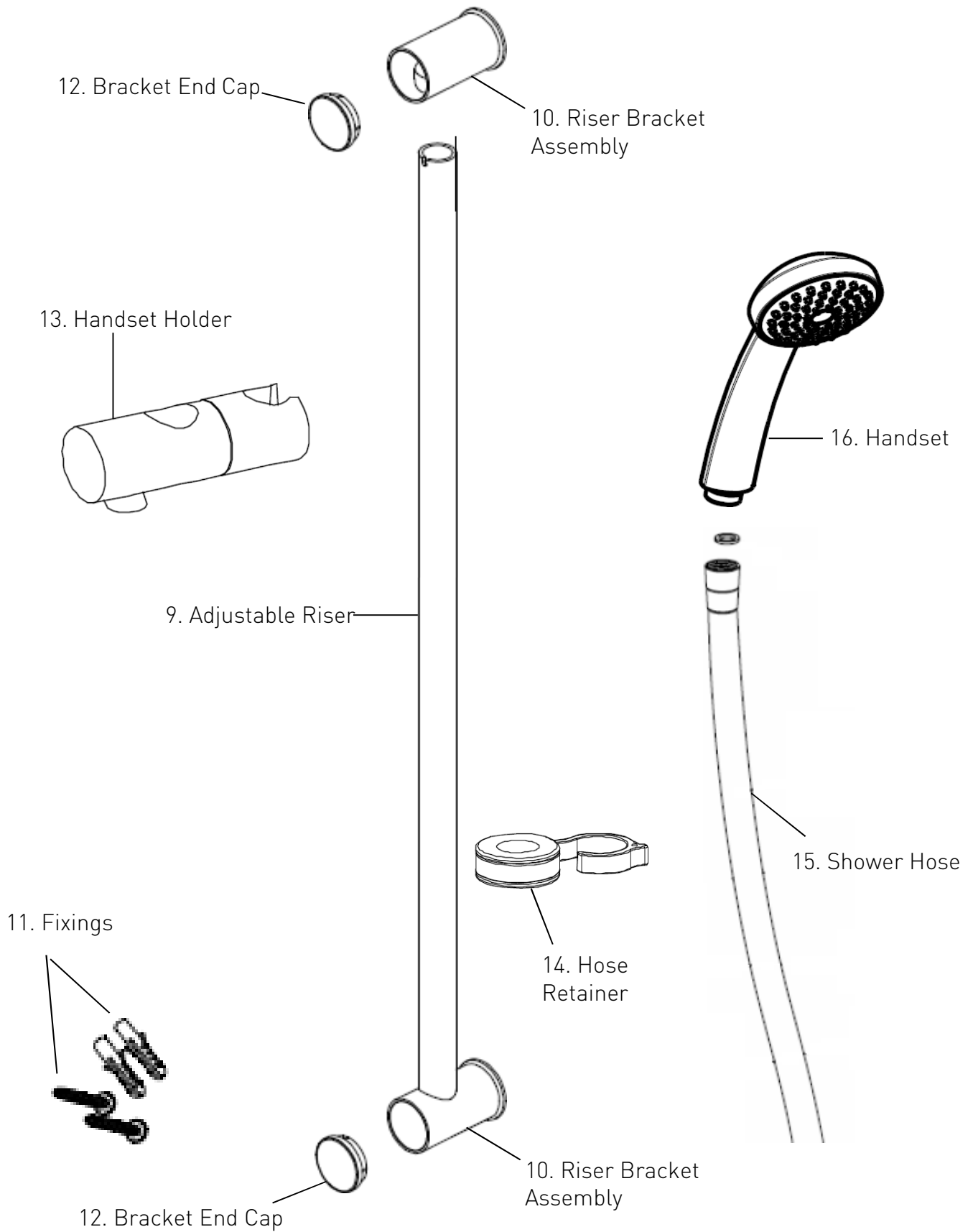

Operation

Flow Control

The flow control handle (on the right) increases and decreases the flow rate through the thermostatic mixer valve. The more the handle is turned the greater the flow rate.

Temperature Control

The temperature control handle (on the left) allows the user to adjust the temperature up to 38° C, however this can be overridden by simply pressing the button on the temperature handle in and continuing to turn the control handle until the desired temperature is achieved. The user can then override the temperature to a maximum of 46°C.

Shower Handset (FZ SHXMMCTFF C Only)

The shower handset supplied with the FZ SHXMMCTFF C has 3 spray modes – spray, jet spray and combination. Simply rotate the spray head one way or the other until it ‘clicks’ into the desired spray pattern.

Setting

The temperature can be adjusted to suit site conditions or personal preference by following the steps below.

- Using a flat bladed tool remove the Handle end cap and loosen the retaining screw.
- Remove the handle by pulling it from the valve spindle.
- Turn the flow of water on to the maximum temperature and wait a few minutes to allow the temperature to stabilize.
- Turn the cartridge spindle in the required direction to increase or decrease the set temperature. Anti-clockwise to increase the temperature, clockwise to decrease.
- Turn the flow of water off.
- Replace the handle, retaining screw and handle cover cap.

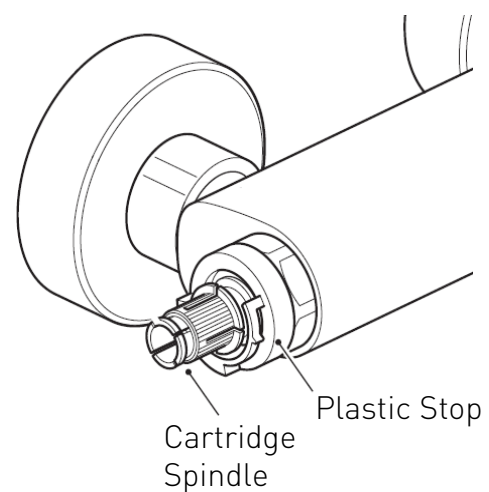

Commissioning

Commissioning notes for Thermostatic Mixing Valves

The first step in commissioning a thermostatic mixing valve is to check the following:

1. The designation of the thermostatic mixing valve matches the application.
2. The supply pressures are within the valves operating range.
3. The supply temperatures are within the valves operating range.
4. Isolating valves (and strainers preferred) are provided.

If all these conditions are met, proceed to set the temperature as stipulated in the setting section.

The mixed water temperature at the terminal fitting must never exceed 46°C.

When commissioning / testing is due the following performance checks shall be carried out:

- Measure the mixed water temperature at the outlet.
- Carry out the cold water supply isolation test by isolating the cold water supply to the TMV, wait for five seconds, if the water is still flowing check that the temperature is below 46°C.

If there is no significant change to the set outlet temperature (+/-2°C or less change from the original setting) and the fail –safe shut off is functioning, then the valve is working correctly and no further service work is required.

Notes: If there is a residual flow during the commissioning or the annual verification (cold water supply isolation test), then this is acceptable providing the temperature of the water seeping from the valve is no more than 2°C above the designated maximum mixed water outlet temperature setting of the valve.

Temperature readings should be taken at the normal flow rate after allowing for the system to stabilise.

The sensing part of the thermometer probe must be fully submerged in the water that is to be tested.

Any TMV that has been adjusted or serviced must be re-commissioned and re-tested in accordance with the instructions in the setting section.

The installation of thermostatic mixing valves must comply with the requirements of the Water Supply (Water Fittings) Regulations 1999.

In-Service Testing

Purpose

The purpose of in service tests is to regularly monitor and record the performance of the thermostatic mixing valve.

Deterioration in performance can indicate the need for service work on the valve and / or water supplies.

Servicing Intervals

To reduce the buildup of lime scale and to ensure this shower works to its maximum performance, we recommend this shower is serviced every 6 – 12 months depending on the hardness of your water.

Procedure

Using the same measuring equipment or equipment to the same specification as used in the commissioning section, adjust the temperature of the mixed water in accordance with the manufactures instructions and the requirement of the application, Carry out the following sequence.

- a) Record the temperature of the hot and cold water supplies.
- b) Record the temperature of the mixed water at the largest draw-off flow rate.
- c) Record the temperature of the mixed water at a smaller draw-off flow rate, which shall be measured.

If the mixed water temperature has changed significantly from the previous test results (e.g. >1K), record the change and before re-adjusting the mixed water temperature check:

- a) That any in-line or integral strainers are clean.
- b) Any in-line or integral check valves or other anti-back siphonage devices are in good working order.
- c) Any isolating valves are fully open.

With an acceptable mixed water temperature, complete the following procedure:

- a) Record the temperature of the hot and cold water supplies.
- b) Record the temperature of the mixed water at the largest draw-off flow rate.
- c) Record the temperature of the mixed water at a smaller draw-off flow rate, which shall be measured.
- d) Isolate the cold water supply to the mixing valve and monitor the mixed water temperature.
- e) Record the maximum temperature achieved as a result of (d) and the final stabilised temperature.
- f) Record the equipment, thermometer etc. used for the measurements.

If at step (e) the final mixed water temperature is greater than 41°C and / or the maximum temperature exceeds the corresponding value from the previous results by more than about 2K, the need for service work is indicated.

Note: In-service tests should be carried out with a frequency, which identifies a need for service work before an unsafe water temperature can result. In the absence of any other instruction or guidance, the procedure described in Annex F of D 08 may be used.

Annex F of D 08 (informative)

Frequency of In-service tests

General

In the absence of any other instruction or guidance on the means of determining the appropriate frequency of in-service testing, the following procedure may be used:

- a) 6 to 8 weeks after commissioning carry out the tests in 'In-Service Tests'.
- b) 12 to 15 weeks after commissioning carry out the tests detailed in 'In-Service Tests'.

Depending on the results of the above tests, several possibilities exist:

- a) If no significant changes (e.g. $<1\text{K}$) in mixed water temperatures are recorded between commissioning and 6 to 8 week testing, or between commissioning and 12 to 15 week testing the next in-service test can be deferred to 24 to 28 weeks after commissioning.
- b) If small changes (e.g. 1 to 2K) in mixed water temperatures are recorded in only one of these periods, necessitating adjustment of the mixed water temperature, then the next in-service test can be deferred to 24 to 28 weeks after commissioning.
- c) If small changes (e.g. 1 to 2K) in mixed water temperatures are recorded in both these periods, necessitating adjustment of the mixed water temperature, then the next in-service test should be carried out at 18 to 21 weeks after commissioning.
- d) If significant changes (e.g. $> 2\text{K}$) in mixed water temperatures are recorded in either of these periods, necessitating service work, then the next in-service test should be carried out at 18 to 21 weeks after commissioning.

Maintenance

General Cleaning

Your fitting has a high quality finish and should be treated with care to preserve the visible surfaces. All surfaces will wear if not cleaned correctly, the only safe way to clean your mixer valve is to wipe with a soft damp cloth. Stains can be removed using washing up liquid. All bath cleaning powders and liquids will damage the surface of your fitting, even the non – scratch cleaners.

Note: Never use abrasive detergents or disinfectants or those containing alcohol, hydrochloric acid or phosphoric acid.



Bristan recommend E-cloth for cleaning all of our bathroom & kitchen products. Using just water, E-cloth gives a smear free, deep clean by breaking up

and holding dirt, which normal cloths leave behind. Order through your Bristanstockist (order code: ECLOTH).

Flow Valve Maintenance

If your shower valve begins to drip it may be due to the flow valve letting water pass through the valve.

Isolate both hot and cold water supplies to the mixer valve by either:

- Turning the water supply off at the mains stopcock or
- Turning off the isolation valves to the mixer valve.

1. Remove the flow control cover cap, loosen the screw and pull the handle off the valve spindle.
2. Using a suitable spanner unscrew the valve out from the body and check its condition.
3. Clean the valve and replace if necessary.

4. Push the handle back onto the valve spindle and replace the handle, screw and handle cover cap.

Cartridge Maintenance

We advise that the shower valve is regularly serviced in hard water areas to maintain optimum performance (see Map of Hard Water Regions in the UK overleaf).

Isolate both hot and cold water supplies to the mixer valve by either:

- Turning the water supply off at the mains stop cock or
- Turning off the isolation valves to the mixer valve.

1. Remove the temperature control cover cap, loosen the screw and pull the handle off the cartridge spindle
2. Remove the plastic stop. Important: Take note of the position of the plastic stop and handle – they must be refitted in the same positions.
3. Unscrew the thermostatic cartridge from the body.
4. Place the cartridge in a bowl and carefully add hot water (just off the boil) and vinegar to de-scale the cartridge. Leave in the solution until the water has cooled and rinse with clean water.
5. Grease the seals with a silicon grease supplied by Bristan (part number: SP-495-0002) and carefully refit.
6. Reset the maximum temperature and refit the handle, screw and handle cover cap.

BRISTAN

Hard Water Regions in the UK

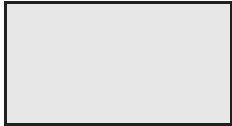

Soft to moderately soft
0 - 100mg/l as calcium carbonate equivalent



Slightly hard to moderately hard
100 - 200mg/l as calcium carbonate equivalent



Hard to very hard
Above 200mg/l as calcium carbonate equivalent

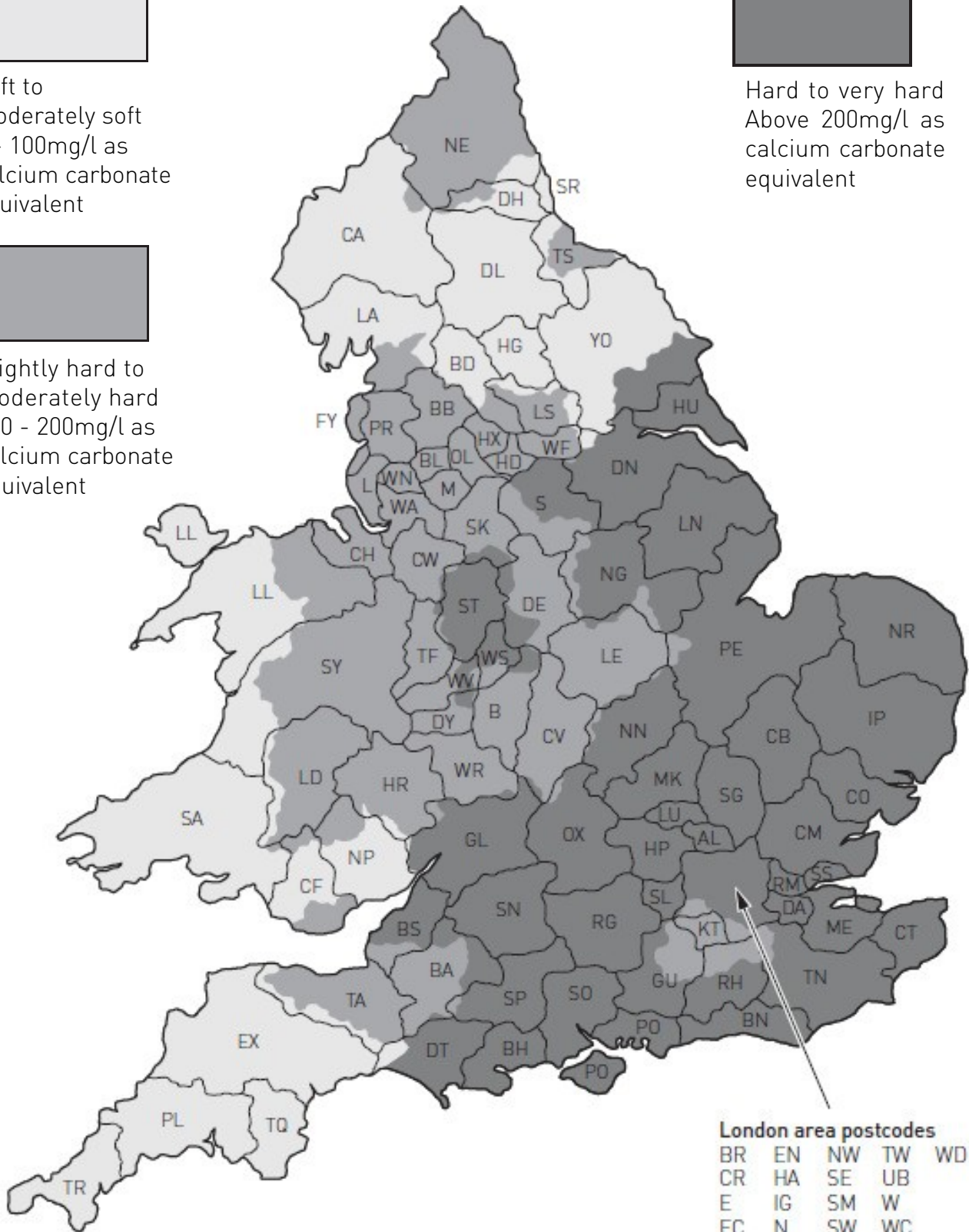

Troubleshooting

Symptom	Cause	Remedy
No flow or low flow rate and / or varying temperatures.	Partially closed stop or service valve in water supply pipework to the mixer valve.	Open stop or service valve.
	Instantaneous water heater cycles on and off as the flow rate or pressure is too low.	Increase water flow rate or pressure through system Contact the boiler manufacturer.
	Head of water is below the minimum distance required.	Refer to the specifications section.
	Inlet filter is partially blocked.	Clean or replace, flush through pipework before refitting.
	Hot or cold water being drawn off elsewhere causing pressure changes or instantaneous boiler changes.	Do not use other water outlets when using the shower valve.
	Make sure the maintained inlet pressures are nominally balanced and sufficient.	If pressures are unbalanced then a pressure reducing valve should be used.
	Airlock or partial blockage of the pipework.	Flush through pipework to ensure removal of debris and any airlocks.
	No hot or cold water reaching the shower valve.	Check hot and cold feeds (the valve will shut down if either the hot or cold supply fails).
Water leaking from showerhead.	This is normal for a short time after turning off.	Adjust the angle of the showerhead as necessary to vary draining time.
	Shower flow control valve failing to close fully, possibly due to water borne debris.	Remove flow control valve assembly and check. Refer to maintenance section (page 23) before dismantling shower valve.
	Flow control valve seals damaged.	Check condition of flow control valve and replace as necessary (refer to maintenance section (page 23)).

Troubleshooting

Symptom	Cause	Remedy
Maximum water temperature too hot or cold.	Maximum water temperature set incorrectly.	Reset maximum water temperature. Refer to 'Setting/Commissioning' sections.
Outlet water temperature too hot / cold.	Inlet filter is partially blocked.	Check insert filters for any blockages and clean as necessary.
	Installation conditions outside operating parameters.	Refer to Installation Requirements (pages 9-12). Service shower valve as recommended. Refer to maintenance section (page 23).
Water temperature too cold – maximum water temperature incorrectly set.	Hot water temperature is less than 10°C above the required blend temperature.	Adjust hot water temperature or wait for water to reheat if stored system is used.
	Instantaneous water heater not igniting because water flow rate is too low.	Increase water flow rate through the system. Check cartridge inlet filters and clean or replace. Refer to maintenance section (page 23). Contact the boiler manufacturer.
	Instantaneous water heater not igniting because water pressure is too low.	Refer to General Information for system requirements. Increase water pressure through system. Contact the boiler manufacturer.
Only hot or cold water from TMV outlet.	Inlet water supplies are reversed (hot to cold supply).	Check the connections are the correct way round. Hot on the left and cold on the right when viewed from the front. Rework pipework as necessary.
	Inlet filter is partially blocked.	Clean or replace, flush through pipework before refitting.

Bristan Guarantee

Bristan offers solid guarantees to provide you with complete peace of mind.

Taps and Mixers

5 year parts and 1 year labour*. Gold, painted and special finishes 3 years parts only.

All subject to proof of purchase.

Mixer Shower Valves

5 year parts. 5 year labour* (subject to registration), or 1 year with proof of purchase.

Gold, painted and special finishes 3 years parts only.

Pumps and Power Showers

2 year parts. 1 year labour* (subject to registration).

Electric Showers/Instantaneous Water Heaters

2 year parts. 1 year labour* (subject to registration).

Accessories

5 year parts only. Includes bathrooms accessories, shower accessories (e.g. hoses, handsets and poles), wastes, WC levers and light pulls. Gold, painted and special finishes 3 years parts only.

Sanitaryware

5 year parts only. Subject to proof of purchase.

Shower Enclosures and Shower Trays

10 year parts (subject to registration), or 2 years with proof of purchase. 1 year labour* (subject to registration), or 1 year with proof of purchase.

Heated Towel Rails

5 year parts only. Gold, painted and special finishes 3 years parts only. All subject to proof of purchase.

*Labour provided by an approved Bristan engineer. Guarantee only applies to products with a manufacturing fault. A deferred payment will be necessary in order to secure any visits by our engineers which will be charged if the problem is found not to be a manufacturing fault. If the fault is found to be down to a manufacturing error, the payment will be released and not charged.

This guarantee applies to products purchased within the United Kingdom or Republic of Ireland, but does not apply to products used commercially.

The guarantee is only available to original purchasers who have proof of purchase.

The installation must allow ready access to all products for the purpose of inspection, maintenance or replacement.

Any part found to be defective during the above guarantee period will be replaced without charge, providing that the product has been installed in accordance with the instructions, used as intended, and regularly serviced.

Servicing should be carried out at regular intervals of no more than 12 months and more frequently in hard water areas (heavy lime scale) areas.

In the unlikely event that any problems are encountered with the product's performance on installation, you must obtain guidance/authorisation from our Customer Service Department, and be able to supply proof and date of purchase, before any remedial action is taken.

The guarantee excludes general wear and tear and damage caused by accident, misuse or neglect, and does not cover the following:

- Components that are subject to general wear and tear such as filters, seals, 'O' rings and washers etc.
- Damage caused by faulty installation
- Damage caused by lime scale or any waterborne debris
- Damage caused by inappropriate cleaning products (see user instructions)
- Damage caused by the use of non-Bristan parts
- The product being used for a purpose other than intended by the manufacturer.

In the interests of continuous product improvement Bristan reserves the right to alter specification as necessary.

If your product is out of its guarantee period, or you would like to extend the guarantee, then please see our [extended warranty offer](#).



Guarantee

BRISTAN

This booklet covers product codes
ZI SHXSMCT C, FZ SHXVOCTFF C, FZ SHXMMCTFF C

Helpline

0844 701 6273

Bristan Group Limited

Birch Coppice Business Park, Dordon, Tamworth, Staffordshire B78 1SG

A Masco Company

Website: www.bristan.com

Telephone: 08447016 274 Facsimile: 0844 701 6275

Email: enquire@bristan.com