

# MINI2 TS1203 CL C COMMERCIAL Shower Range

## MINI TS1203 Concealed Shower Valve with Lever Chrome



### Specification

Finish/Colour:	Chrome Plated
Main Construction Material:	Brass
No of Controls:	1
Shower Type:	Sequential Mini Valve
Shower Head Type:	Valve Only
Shower Kit:	N/A
Valve/Cartridge Type:	Sequential Cartridge
Maximum Hot Water Supply Temperature °C:	60
Plumbing System Suitability:	Suitable for high pressure systems only
Minimum Dynamic Pressure (bar):	1
Maximum Dynamic Pressure (bar):	5
Maximum Static Pressure (bar):	10
Connection Inlet:	15mm Compression
Connection Outlet:	G 1/2"
Isolation Valve Included:	No
Check Valve Included:	Yes

### Features:

- Single sequential control for both temperature and flow
- Concealed shower with easy-access cover plate for servicing
- Integral isolator and easy clean filters
- Inlet centres of 99mm +/- 1mm

### Product Certifications:



WRAS Certificate No: 240403011  
WRAS Expiry Date: 30/04/2029



TMV2 Certificate No: 2503305  
TMV2 Designation: HP-SE  
TMV2 Expiry Date: 16/03/2030

For more products, visit our website:  
<http://www.bristan.com>

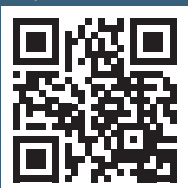

### Dimensions (measurements in mm)

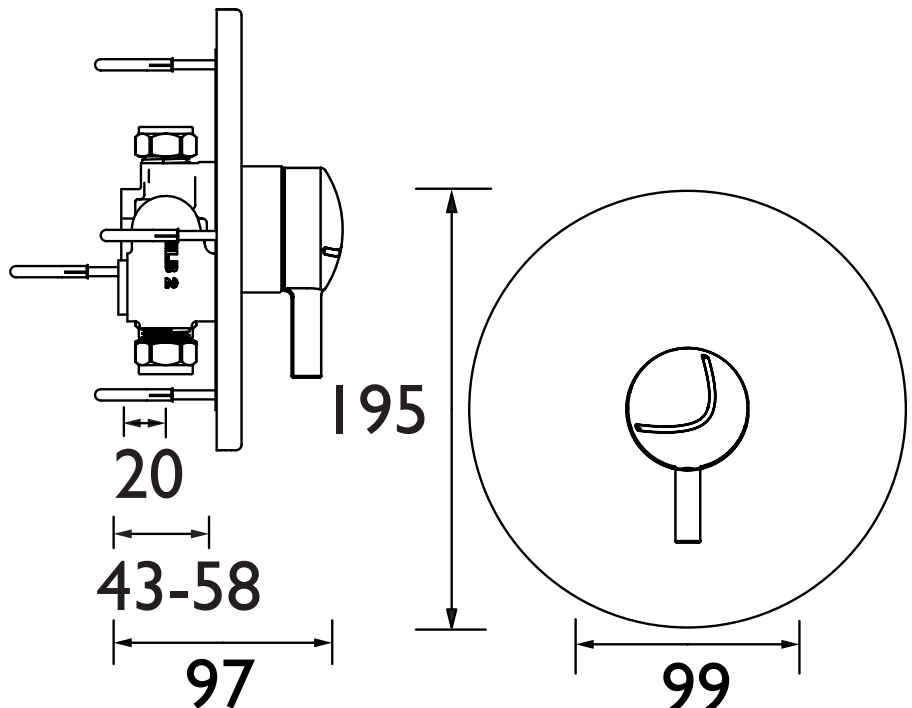

### Flow Rates (l/min)

System Pressure (bar)	1	2	3	4	5
Valve Only (mixed)	7.8	8.8	9.1	9.4	9.3

# TECHNICAL DATA SHEET



# BRISTAN

D8