

VAL WMSNK C CD

LEVER Tap Range Lever Wall Mounted Sink Mixer with Ceramic Disc Valves Chrome



Specification	
Style:	Contemporary
Product Type:	Kitchen Taps
Finish/Colour:	Chrome
Main Construction Material:	Brass
Mount Type:	Wall Mounted
Handle Type:	Lever
Connection Inlet:	1/2" BSP
Number of Tap Holes Required:	2
Valve/Cartridge Type:	1/2" Ceramic Disc Valves
Plumbing System Suitability	All - Ideally balanced
Working Pressure Range:	Min 0.2 Bar, Max 8.0 Bar
Maximum Hot Water Temperature: °c	65
Maximum Dynamic Pressure: (bar)	8
Maximum Static Pressure: (bar)	10
Flow Type:	Dual Flow
Flow Rate: (l/min @ 3 bar)	57.4
Connection Outlet:	
Isolation Included:	No

Features:

- Dual flow
- Supplied with 3"(76mm) metal levers
- Supplied with metal fixing nut
- Chrome plated to BS EN 248

Product Certifications:

WRAS Certificate No: 1605054
WRAS Expiry Date: 31/05/2021



For more products, visit our website:

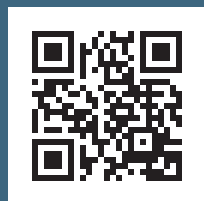

Dimensions (measurements in mm)

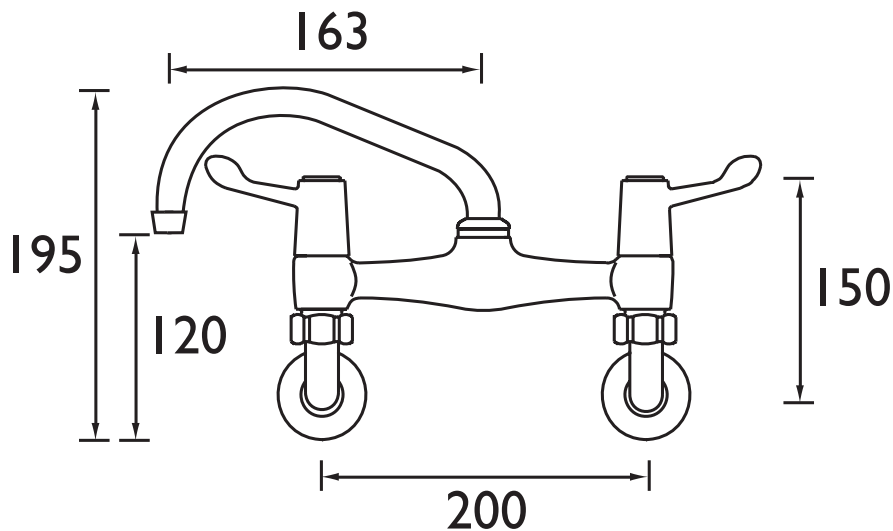

Flow Rates (l/min)

System Pressure (bar)	0.2	0.5	1	2	3	5
VAL WMSNK C CD	8.9	14.3	19.5	28.5	34.9	45

TECHNICAL
DATA
SHEET



BRISTAN
TAPS & SHOWERS

D5