

---

# BRISTAN

---

Prism Basin & Bath Tap Range

Installation Instructions & User Guide



Please keep these instructions for future reference and request of replacement parts

# BRISTAN

## Introduction

Thank you for choosing Bristan, the UK's leading taps and showers expert. We have designed this product with your enjoyment in mind. To ensure that it works to its full potential, it needs to be fitted correctly. These fitting instructions have been created to give you all of the information you need and, if you need any further help, please do not hesitate to give us a call on 0330 026 6273

## Water Pressure

These taps are suitable for use at all supply pressures. If the taps are installed at low pressure (tank fed), then the Minimum height from the outlet of the nozzle to the underside of the cold tank should be 1.8 metres to ensure adequate performance.

These taps should be installed in compliance with Water Regulations. For further details contact your Local Water Authority.

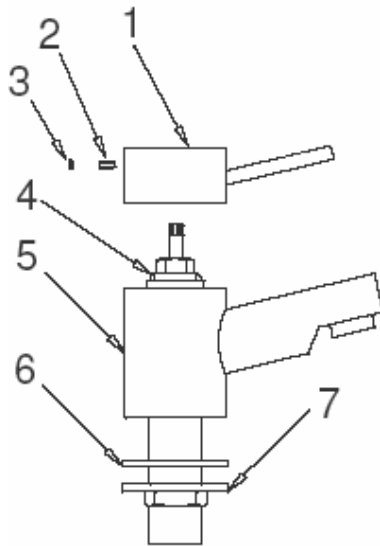

## CONTENTS

1.	Head	(x2)
2.	Grub screw	(x2)
3.	Cap	(x2)
4.	Valve	(x2)
5.	Body	(x2)
6.	Washer	(x2)
7.	Backnut	(x2)

## Installation

### IMPORTANT - PLEASE READ

These fittings need to be installed in accordance with the following Installation Requirements and Notes (IRN) to ensure they meet the requirements of the Water Supply (Water Fittings) Regulations 1999 and the Scottish Byelaws 2004.

IRN R001

See text of entry for Installation Requirements or Notes.

IRN R006

This tap or combination tap assembly has a Type AUK3 air gap and is therefore for installation in any premises to protect against a backflow risk up to a Fluid Category 5.

1. Identify all components and check for completeness, particularly before arranging fitting.
2. Install the taps (5) into the basin or bath using the washers (6) between the tap and basin or bath and backnuts (7) provided.
3. Connect the hot and cold water supplies using suitable connector (not supplied)
4. Turn on water supplies. Open both taps letting the water flow for a few minutes to check all joints and connections for leaks.

## Cleaning & Maintenance

Your fitting has a high quality finish and should be treated with care to preserve the visible surfaces.

All finishes will wear if not cleaned correctly. The only safe way to clean your product is to wipe with a soft damp

cloth. Stains can be removed using washing up liquid. All bathroom cleaning product (powders and liquids) will damage the surface of your fitting, even the non-scratch cleaners.

NOTE:- Never use abrasive detergents or disinfectants or those containing alcohol, hydrochloric or phosphoric acid.

We advise that your fitting is regularly serviced, particularly in hard water areas.

### Maintenance

If the tap begins to drip:

1. Turn off the water supply.
2. Remove cap (3), loosen grub screw (2) with 2.5mm hexagon key and pull off head (1).
3. Remove Valve (4).
4. Carefully clean seating, rubber washer and ceramic disc. Replace valve and head and turn on water supply.

If the issue persists please contact on customer services helpline.

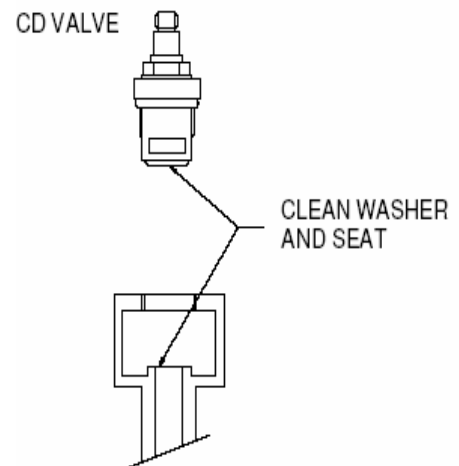

Please Note: in the unlikely event you find a part missing please contact our customer service help line on 0330 026 6273

Your fitting has a high quality finish and should be treated with care to preserve the visible surfaces. All surfaces will wear if not cleaned correctly, the only safe way to clean your tap is to wipe with a soft damp cloth. Stains can be removed using washing up liquid. All bath cleaning powders and liquids will damage the surface of your fitting even the non-scratch cleaners.

# **BRISTAN**

## **Bristan Guarantee**

At Bristan, we want to make things as easy as possible for our customers. That's why we offer solid guarantees on all our products, effective from the date of purchase, to give you peace of mind.

To start your free guarantee, simply scan the QR code and register your product.

Alternatively, visit [www.bristan.com/register](http://www.bristan.com/register) to register your product via a computer.

For full guarantee terms and conditions visit, [www.bristan.com/guarantees](http://www.bristan.com/guarantees)



*We Know & We Care*

### **TELEPHONE HELPLINE: 0330 026 6273**

Bristan Group Limited

UK: Bristan Group

B78 1SG

EU: Masco Group S.à.r.l

14 Rue Strachen

6933 Mensdorf

Luxembourg