

# BRISTAN

**Self – Closing Taps**

**Z ½ C & VA NC ½ C**

**Installation Instructions & User Guide**



**IMPORTANT:** Please keep these instructions for future reference and request of replacement parts

# BRISTAN

<b>Contents</b>	<b>Page</b>
1. Introduction	03
2. Safety Note	03
3. Specification	04
4. Installation	04 - 05
5. Cleaning & Maintenance	06
6. Bristan Guarantee	07

## 1. Introduction

Thank you for choosing Bristan, the UK's leading taps and showers expert. We have designed this product with your enjoyment in mind. To ensure that it works to its full potential, it needs to be fitted correctly. These fitting instructions have been created to give you all of the information you need and, if you need any further help, please do not hesitate to give us a call on 0844 701 6273.

## 2. Safety Note

Please read these instruction thoroughly and retain for future use.

All product manufactured and supplied by Bristan are safe provided they are installed correctly, used correctly and receive regular maintenance in accordance with these instructions.

These fittings need to be installed in accordance with and meet the requirements of the Water Supply (Water Fittings) Regulations 1999 and Scottish Byelaws 2004.



Before starting any installation please consider the following:

Prior to drilling into walls, check that there are no hidden electrical wires, cables or water supply pipes. This can be checked with the aid of an electronic detector.

If power tools are used do not forget to:

- Wear eye protection
- Unplug equipment after use

## 3. Specification

	Min.	Max.
Operating pressure range (bar)		
Z ½ C (Single tap)	0.2	3.0
VA NC ½ C (Pair)	0.2	3.0

Designed to comply with BS EN 816 Sanitary tapware Automatic Shut Off Valves and to be used within systems designed to BS 6700.

BS 6700 recommends the temperature of stored water should never exceed 65°C. A stored water temperature of 60°C is considered sufficient to meet all nominal requirements and will minimise the build up of lime scale in hard water areas.

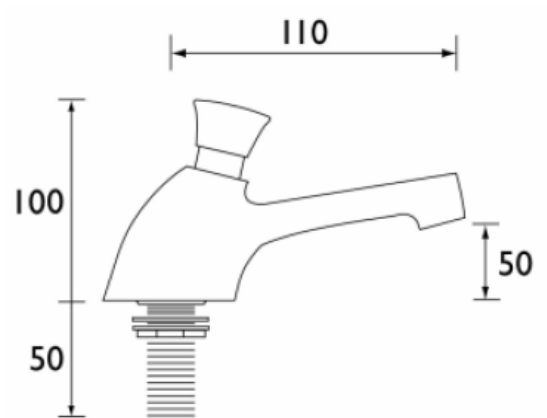

## 4. Installation

If the fitting is installed at low pressure (tank fed), then the minimum distance from the highest installed position of the outlet to the underside of the cold water tank should be at least 2 metres to ensure adequate performance.

**Operating pressures: Min 0.2 bar, Max 3.0 bar**

NOTE:- If the supply pressure is above 1.0 bar it may be advisable to fit the 8 litre per minute flow limiter. The flow limiter should be fitted to the tail of the tap with the arrow pointing upwards and the 'o' ring at the base.

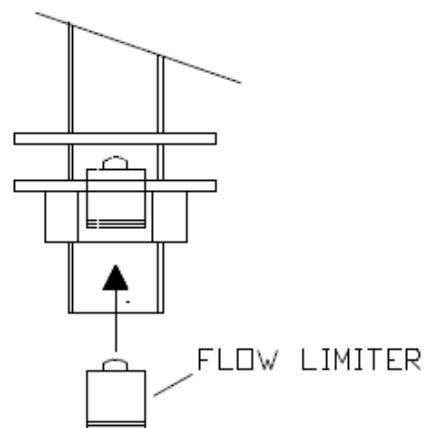
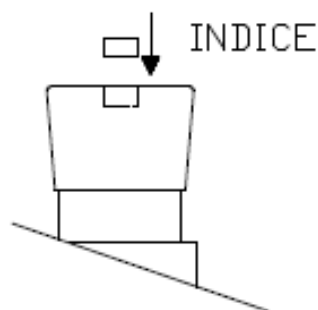

## Installation continued

1. Identify all components are present prior to installation.
2. Assemble and fix the taps as shown in the relevant diagram.
3. Connect water supply to the tap/s. If the supply pressure is above one bar it may be advisable to fit the flow limiter. The flow limiter should be fitted to the tail of the tap with the arrow pointing upwards and the 'o' ring at the base.
4. The tap/s are supplied with two sets of red and blue indices, for either all hot or cold use. Please ensure that the correct indice is fitted to the correct tap.
5. Turn the water supplies on and operate the tap several times to flush the system.
6. Check all joints and connections for leaks.

NOTE:- If the supply pressure is above 3 bar a pressure reducing valve must be fitted. All supply pipework should be thoroughly flushed before connecting to the tap/s to remove any debris in the pipework. Tap/s should also be installed without using of any sealants. Waterborne debris may damage internal parts. Damage caused by waterborne debris will invalidate the guarantee.

### Parts contents list

1. Indices (pair)	x 1
2. Flow limiter	x 2
3. Backnut	x 2
4. Washer	x 2
5. Anti splash	x 2
6. Self closing valve	x 2

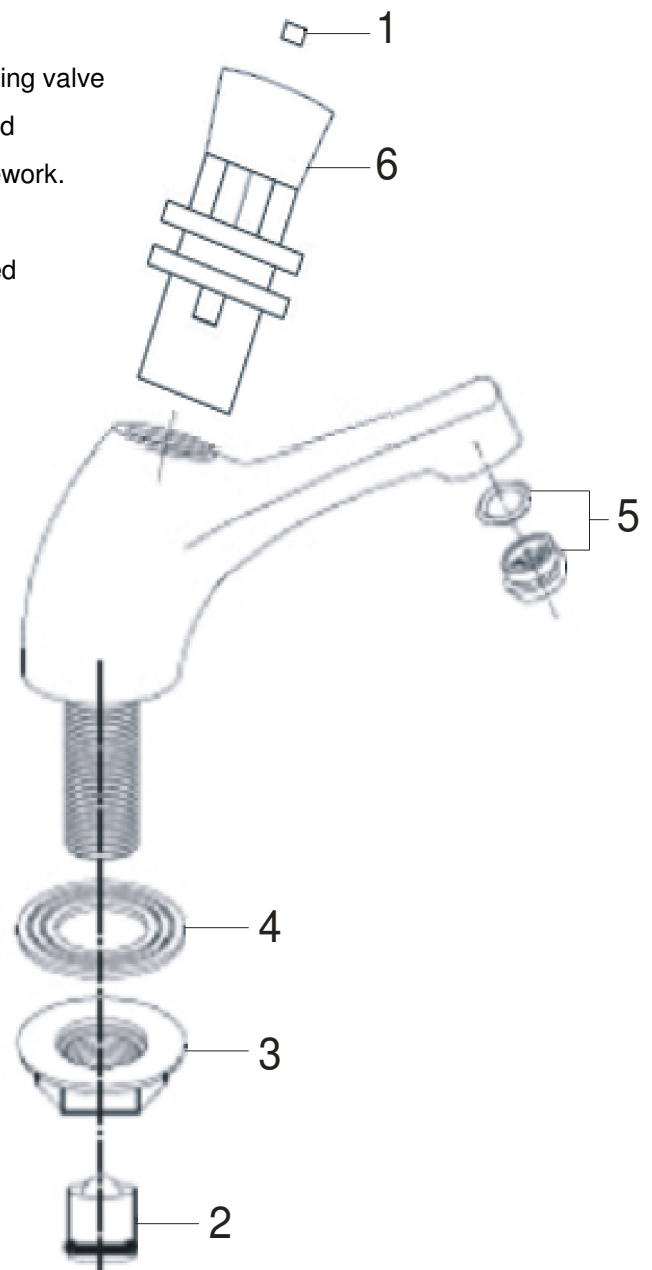

## 5. Cleaning & Maintenance

Your fitting has a high quality finish and should be treated with care to preserve the visible surfaces.

All finishes will wear if not cleaned correctly. The only safe way to clean your product is to wipe with a soft damp cloth. Stains can be removed using washing up liquid. All bathroom cleaning product (powders and liquids) will damage the surface of your fitting, even the non-scratch cleaners.

NOTE:- Never use abrasive detergents or disinfectants or those containing alcohol, hydrochloric or phosphoric acid.

We advise that your fitting is regularly serviced, particularly in hard water areas.

### Maintenance

If the fitting begins to drip:

1. Turn off water supply.
2. Remove the indice (1) and then remove handle and cartridge assembly (2) by unscrewing from the body (3).  
Using a suitable spanner, remove the valve. Once removed, carefully clean the valve, seals and all components.
3. Replace all of the above and turn on water supply.
4. If the problem persists contact our helpline.

Bristan recommend E-Cloth for cleaning all of our bathroom & kitchen products. Using just water, E-cloth gives a smear free, deep clean by breaking up and holding dirt, which normal cloths leave behind. Order through your Bristan stockist.

(ORDER CODE: ECLOTH)



## 6. Bristan Guarantee

2 year -

### Pumps, Power Showers

2 year parts. 1 year labour (subject to registration).

### Electric Showers/Instantaneous Water Heaters

2 year parts. 1 year labour (subject to registration).

5 year -

### Taps and Mixers

5 year parts and 1 year labour (subject to proof of purchase).

### Shower Valves

5 year parts. 5 year labour (subject to registration), else 1 year with proof of purchase.

### Accessories

5 year parts only. Includes bathrooms accessories, shower accessories (e.g. hoses, handsets and poles), wastes, WC levers and light pulls.

10 year -

### Shower enclosures, Shower Trays, Sanitary Ware & Furniture

10 year parts (subject to registration), else 2 years with proof of purchase. 1 year labour (subject to registration), else 1 year with proof of purchase.



**Guarantee**

This guarantee applies to products purchased within the United Kingdom or Republic of Ireland, but does not apply to products used commercially.

The guarantee is only available to original purchasers who have proof of purchase.

The installation must allow ready access to all products for the purpose of inspection, maintenance or replacement.

Any part found to be defective during the above guarantee period will be replaced without charge, providing that the product has been installed in accordance with the instructions, used as intended, and regularly serviced.

Servicing should be carried out at regular intervals of no more than 12 months and more frequently in hard water areas (heavy lime scale) areas.

In the unlikely event that any problems are encountered with the product's performance on installation, you must obtain guidance/authorisation from our Customer Service Department, and be able to supply proof and date of purchase, before any remedial action is taken.

The guarantee excludes general wear and tear and damage caused by accident, misuse or neglect, and does not cover the following:

Components that are subject to general wear and tear such as filters, seals, 'O' rings and washers etc.

- Damage caused by faulty installation
- Damage caused by lime scale or any waterborne debris
- Damage caused by inappropriate cleaning products (see user instructions)
- Damage caused by the use of non-Bristan parts
- The product being used for a purpose other than intended by the manufacturer.

In the interests of continuous product improvement Bristan reserves the right to alter specification as necessary.



**Guarantee**



**Guarantee**



**Guarantee**

# BRISTAN

This booklet covers product codes

Z ½ C

VA NC ½ C

**Helpline**

**0844 701 6273**

Bristan Group Limited

Birch Coppice Business Park, Dordon, Tamworth, Staffordshire B78 1SG

A Masco Company

Website: [www.bristan.com](http://www.bristan.com)

Telephone: 0844 7016 274      Facsimile: 0844 701 6275

Email: [enquire@bristan.com](mailto:enquire@bristan.com)