

# VAC 1/2 C MT

## CLUB Tap Range Club Basin Taps with Metal Heads Chrome



### Features:

- Robust metal fixing nut to secure the tap in place reducing the risk of loosening over time.
- A hard-wearing, flawless, scratch resistant chrome finish that lasts for years. Salt spray tested to ensure added durability.
- 5 year parts and 1 year labour guarantee for peace of mind.
- Co-ordinating Bathroom taps and Accessories available

### Product Certifications:



WRAS Cert. Number: 250403012  
WRAS Expiry Date: 17/04/2025



For more products, visit our website:  
<http://www.bristan.com>



### Specification

Product Type:	Bathroom Taps
Main Construction Material:	Brass
Mount Type:	Deck Mounted
Handle Type:	Hand Wheel
Connection Inlet:	1/2" BSP
Connection Outlet:	M16 Aerator
Number of Tap Holes:	2
Valve/Cartridge Type:	1/2" Standard Valve
Plumbing System Requirements:	Suitable for all plumbing systems
Minimum Dynamic Pressure:	0.2 Bar
Maximum Dynamic Pressure:	5.0 bar
Maximum Hot Water Temperature: °C	65
Maximum Static Pressure: (bar)	10
Flow Type:	Single Flow
Isolation Included:	No

### Dimensions (measurements in mm)

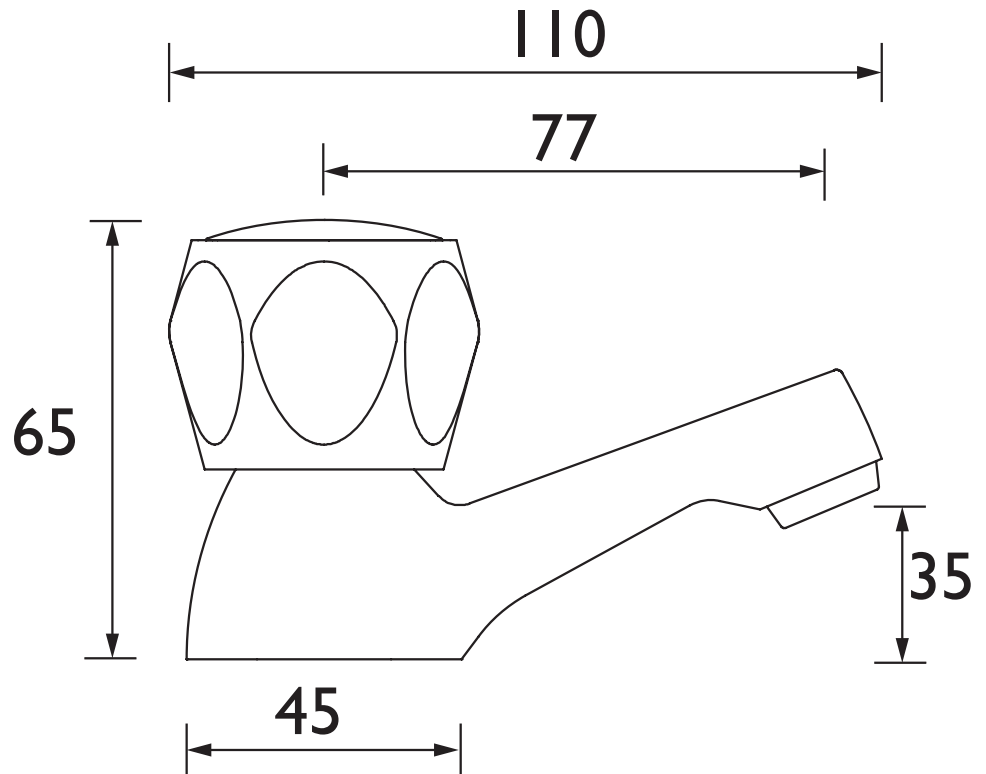

### Flow Rates (l/min)

System Pressure (bar)	0.2	0.5	1	2	3	5
VAC 1/2 C MT	14	22.1	31	44.3	54.2	70

## TECHNICAL DATA SHEET



# BRISTAN

D9